

REVISIONS				
ZONE	REV.	DESCRIPTION	DATE	APPROVED
	A	INCREASED OVERALL LENGTH TO ACCOMMODATE NEW PRESSURE VESSELS	9/27/2019	CO

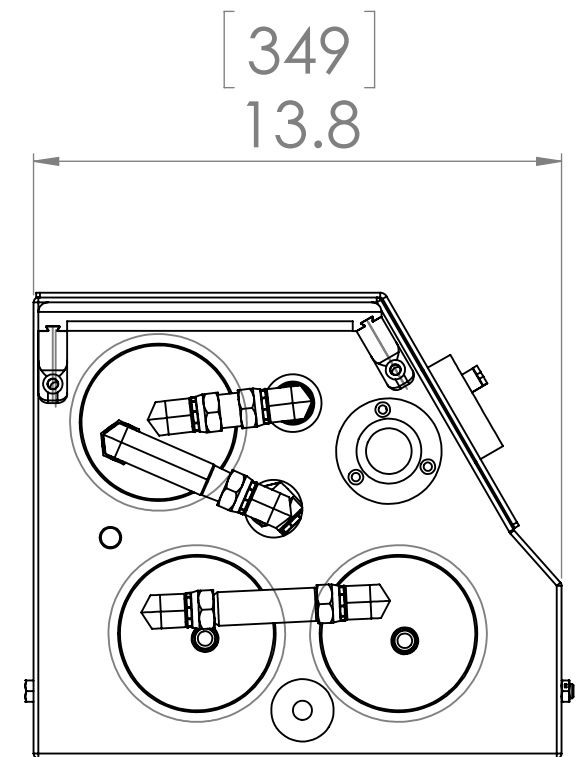
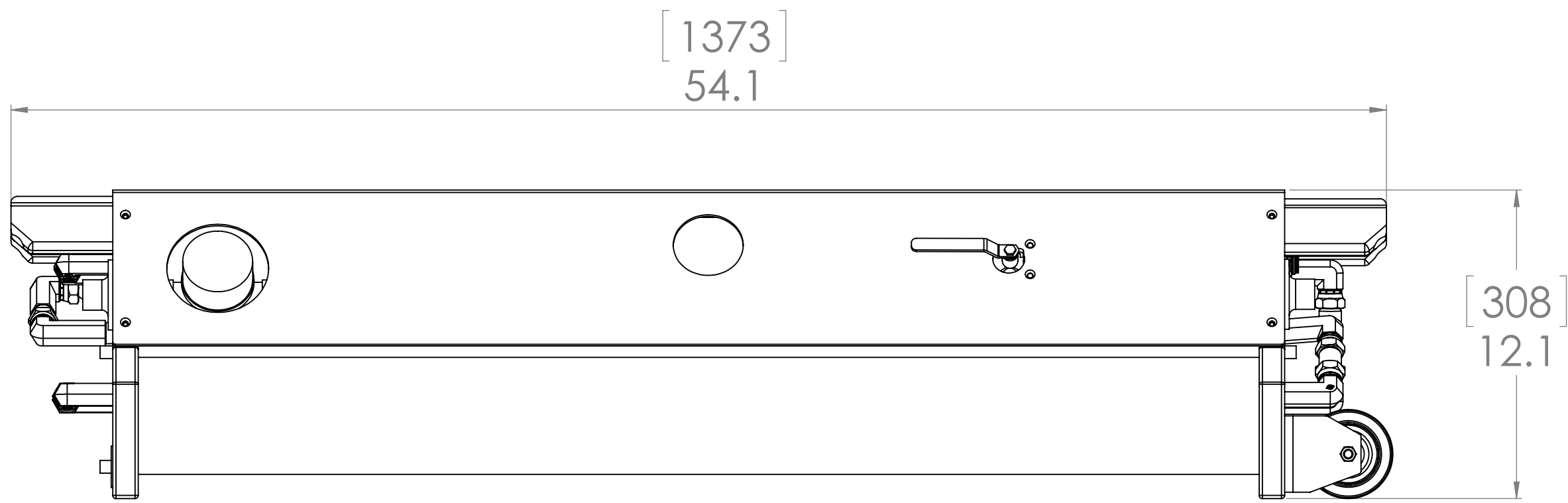
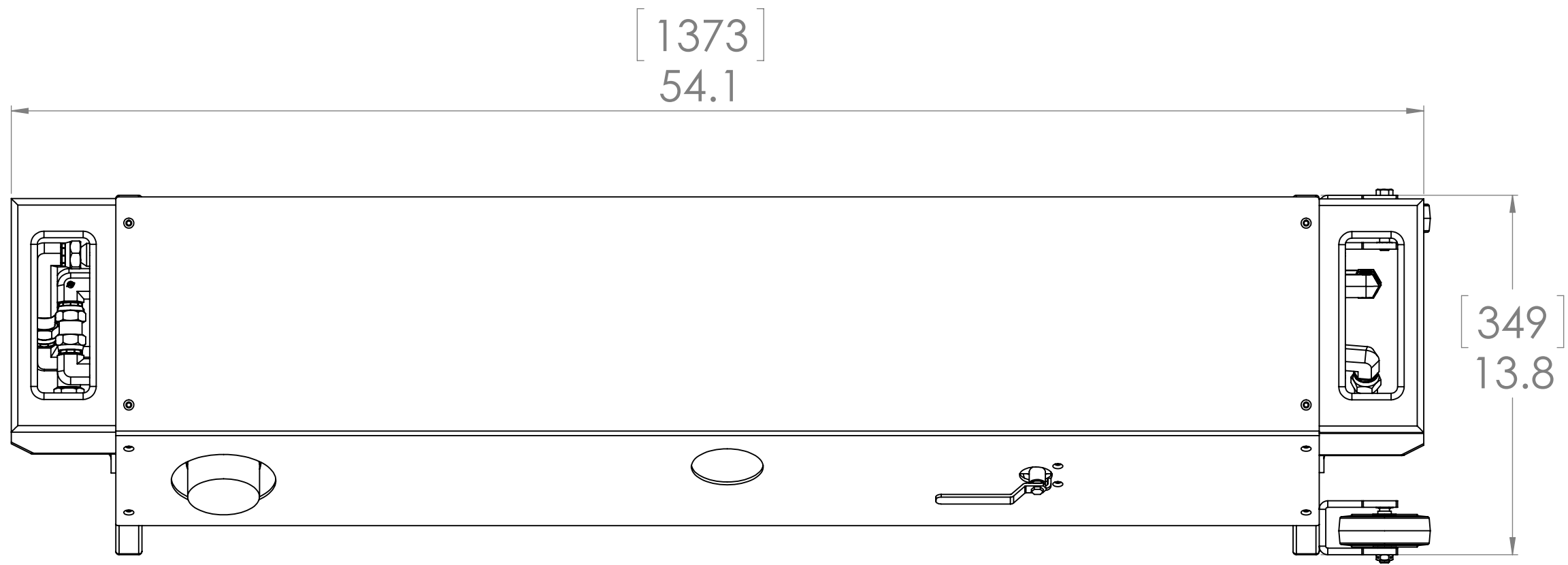

NOTICE OF CONFIDENTIALITY
 THE INFORMATION CONTAINED IN THIS DRAWING IS THE SOLE PROPERTY OF BLUE WATER DESALINATION LLC. ANY REPRODUCTION, CIRCULATION, AND DISTRIBUTION IN PART OR AS A WHOLE WITHOUT THE WRITTEN CONSENT OF BLUE WATER DESALINATION LLC IS STRICTLY PROHIBITED.

MATERIAL:
 FINISH:
 DO NOT SCALE DRAWING

TOLERANCES
 UNLESS OTHERWISE SPECIFIED:
 DIMENSIONS ARE IN INCHES AND MILLIMETER

FRACTIONAL:	± 1/16"	± 1.5mm
ANGULAR:	± 0.1°	± 2.5mm
.XX	± .001"	± 0.50mm
.XXX	± .005"	± 0.127mm

APPROVALS	DATE
DRAWN	
CHECK	
MFG	
QUAL	
CHIEF	

Blue Water
 DESALINATION

1930 E. CARSON ST, SUITE 103
 CARSON, CA, 90810
 TEL: 1 (855) 55 DESAL
 FAX: 1 (310) 684-1474
 www.BlueWaterDesalination.com

TITLE: **CLEARMATE MOBILE**

SIZE	DRAWING NUMBER	REV
C	CMM1M	A
SCALE:	WEIGHT:	SHEET 1 OF 1