

Now With Titanium

Eskimo Ice EI540X Fishbox Ice System

Titanium Durability & 540 lbs/245 kg Of Fishbox Ice Per Day



EI540X shown with and without cover panels

The Eskimo Ice EI540X system produces up to 540 lbs/245 kg of fishbox ice per day, and has a titanium condensing coil for greater durability. The EI540X ice-making machine comes in a self-contained, cube-shaped package with a 16.25 x 16.25 in/413 x 413 mm footprint, making it ideal for boats with limited installation space but no less demand for reliable and efficient fishbox ice production.

EI540X units are easy to install. Ice is generated minutes after starting the system, and can be conveyed up to 35 ft/10.6 m through an ice-delivery hose to nearly any desired location on board.

Titanium durability extends the service life of the condenser for many years of worry-free operation. This is because titanium is unaffected by the punishing combination of saltwater, invasive marine life, and the harsh acids used for routine cleaning of the condenser coil.

The system is operated by the Smart Logic control. The control is integrated into the electrical box which can be mounted remotely for installation flexibility. Smart Logic features a full menu of sensors and status lights monitor gas pressure, auger motor, compressor, water level, ice level, and ice clogs, and will shut off the system if problems are detected.

EI540X units feature ventilated cover panels, which can be easily removed for convenient service access from any side.

The EI540X system installation kit includes one electrical box with Smart Logic keypad/display, water filter, and 35 ft/10.6 m of 0.75 in/20 mm ID ice delivery hose and insulation. This smaller diameter hose is easier to install and less likely to kink. Units are available in 115V/60Hz, 230V/60Hz, and 220V/50Hz electrical configurations. The EI540X will support an additional remotely-mountable Smart Logic keypad/display, which can be purchased separately.



Ventilated cover panels can be removed for service access from any side.



The easy-to-use Smart Logic digital control can be mounted remotely.



Thermal expansion valve increases performance for all conditions.

Key Benefits

- Produces up to 540 lbs/245 kg of fishbox ice per day
- Titanium durability extends service life of the system
- Thermal expansion valve increases performance for all conditions
- Compact footprint - 16.25 x 16.25 in/413 x 413 mm
- Operates up to two remote-mounted Smart Logic digital controls/display panels
- Conveys ice 35 ft/10.6 m through insulated delivery hose
- Sensors monitor all system functions
- Monitor system and restart from any Smart Logic digital control location
- Ventilated cover panels can be removed for maintenance access from any side
- CAN Bus compatible
- Optional STIIC access
- Smaller 0.75 in/20 mm ID ice delivery hose is easier to install, less likely to kink
- Available in 50Hz and 60Hz models

Special Options

- Pump kit

Product Testimonial

"It can fill a five-gallon bucket in under an hour. It doesn't get any better. Sushi quality fish all the time."

— Capt. Glenn Morgan, Carpe Momentum

"We recently installed an Eskimo Ice machine on the Big Oh and it provides us with professionally crushed ice to keep our bait and our fish fresh while we're fishing tournaments all over the world. I would not have a boat without an Eskimo Ice maker."

— Capt. Ronnie Fields, In The Bite Magazine's 2010 Captain of the Year



Specifications for Eskimo Ice EI540X Fishbox Ice System

Model	EI540X-115V	EI540X-220V	EI540X-230V
Ice Capacity Per Day (lbs/kg) ⁽¹⁾	540/244.1	540/244.1	540/244.1
Ice Capacity Per Hour (lbs/kg) ⁽¹⁾	22/9.1	22/9.1	22/9.1
Voltage (V)	115	220	230
Cycle (Hz)/Phase (Ph)	60/1	50/1	60/1
Full Load Amps (FLA) Cool (A)	10.7	5.4	5.3
Locked Rotor Amps (LRA) (A)	58.8	26.3	31
Max. Circuit Breaker (A)	30	15	15
Min. Circuit Ampacity (A)	18	10	10
Refrigerant Type	404A	404A	404A
Water Consumption Per Day/24 Hours (gal/l)	64.7/244.1	64.7/244.1	64.7/244.1
Height (in/mm) ⁽²⁾	16.25/413	16.25/413	16.25/413
Width (in/mm) ⁽²⁾	16.25/413	16.25/413	16.25/413
Depth (in/mm) ⁽²⁾	16.25/413	16.25/413	16.25/413
Seawater Inlet Connection (in)	5/8	5/8	5/8
Net Weight (lbs/kg) ⁽³⁾	107/48.6	107/48.6	107/48.6
Gross Weight (lbs/kg) ⁽³⁾	128/58.1	128/58.1	128/58.1

¹ Actual capacity depends upon conditions
² All dimensions ± 0.30 in. (8 mm).
³ All weights ± 10%

Dimensions

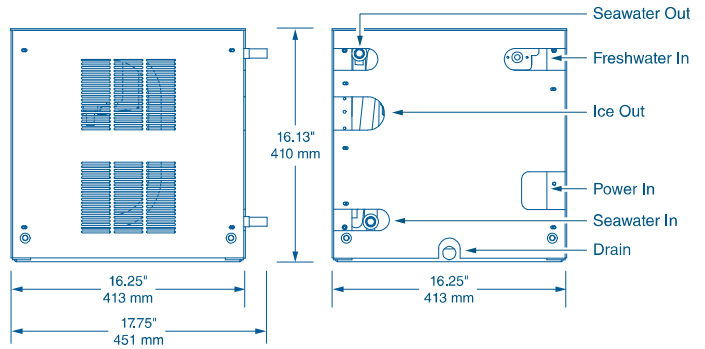

Optional Pump Kits

- 115V/60Hz - P/N 252000572
- 220V/50-60Hz - P/N 252000571

Installation

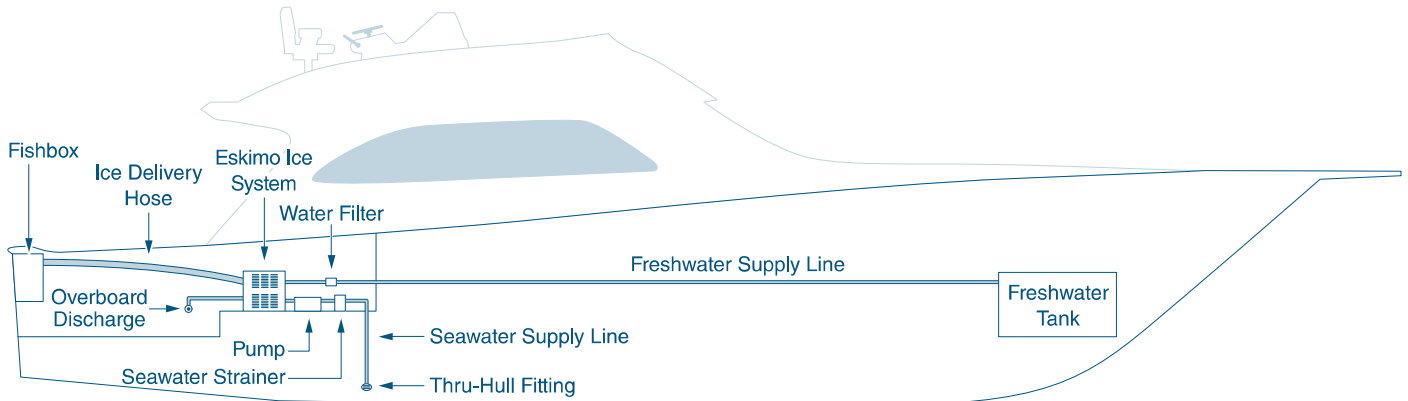

DOMETIC MARINE DIVISION

2000 N. Andrews Ave. Ext. | Pompano Beach, FL 33069 USA | Tel. 954-973-2477 | Fax: 954-979-4414
 www.Dometic.com/Marine | MarineSales@DometicUSA.com

24/7 TECH SUPPORT FOR UNITED STATES & CANADA:

8:00 AM to 5:00 PM Eastern Time: 800-542-2477
 After hours and weekends: 888-440-4494

INTERNATIONAL SALES & SERVICES

Europe & the Middle East: Call +44(0)870-330-6101
 For all other areas visit our website to find your nearest distributor.

Dealer

