

REU Series DX Evaporators

With High-Efficiency Blowers



REU16 Evaporator shown

Cruisair's REU Series evaporators are draw-through, ductable cooling units with rotatable, variable-speed blowers. Featuring high-efficiency blowers, REU series units are available in capacities from 7K to 36K BTU/hr. Electric heat is standard on RHEU models (7K to 16K BTU/hr.). REU units can be used with Cruisair R-22 or R-417A condensers.

The REU Series was designed for installation low in a closet, cabinet, or other enclosed space, with discharge air ducted to one or more grilles high in the cabin. One or two evaporators can be used with a single Cruisair type condensing unit of matched capacity. Please contact the Cruisair Applications department for assistance in design prior to installation.

REU units can be used with a combination of plenums and flexible duct, or built-in ductwork may be used. The included hose adapter is used to connect flexible duct to the blower outlet. If you are using built-in ductwork, a flexible transition between the blower and duct should be installed.

Vibration-isolation mounting is built into each unit to simplify installation. The blower is supported by a sturdy aluminum bracket with isolation grommets to reduce possible vibration. The blower performs favorably in higher static pressure conditions. The internal motor housing results in a narrower unit and promotes quieter operation.

The condensate pan, blower housing, and all other metal surfaces over which air passes are covered with insulating foam which reduces noise and secondary condensation.

The "positive flow" condensate drain pan has an anti-slosh, antifungal foam lining.

Continued on reverse side

Key Benefits

- Compact ductable cooling or heating unit.
- Rotatable, variable speed blower.
- Insulated condensate pan with anti-slosh, antifungal foam lining.
- High-efficiency blower.
- Air filter included.
- "Positive Flow" drain pan.
- High-efficiency evaporator coil.
- Larger blower inlet for increased air flow across coil.
- Single piece shroud and coil enclosure.
- Hose adapter included.
- Blower bracket with vibration isolation grommets installed.
- Increased metal thickness on structural parts for strength.
- For use with water-cooled and air-cooled condensers. Air-cooled product line is limited to models 7K-16K.

Cruisair REU evaporators can be controlled using the SMXht or SMXir keypad displays operating on the SMXII or SMXNet control systems, or using the Qht or Q3 keypad displays

operating on the Q-Logic control system. A mechanical rotary-knob switch assembly is also available.

Technical Specifications for REU Series DX Evaporators

| Model | Capacity (BTU/hr) | Voltage (50/60Hz) | Blower Amps | Air Flow (cfm/m ³ h) | Electric Heat (kW/Amps) | Dimensions (in/mm) | | | Weight (lb/kg) |
|-----------------------------------|-------------------|-------------------|--------------|---------------------------------|-------------------------|--------------------------|-----------|-----------|----------------|
| | | | | | | Height ⁽¹⁾ | Width | Depth | |
| RHEU7 RHEU7C | 7,000 | 115 230 | 1.74 0.98 | 233/395.91 | 1.0/8.70 1.0/4.35 | 11.25/286 | 13.75/350 | 12.00/305 | 14.00/6.35 |
| RHEU8 RHEU8C | 8,000 | 115 230 | 1.74 0.98 | 266/451.99 | 1.0/8.70 1.0/4.35 | 11.25/286 | 13.75/350 | 12.00/305 | 14.00/6.35 |
| RHEU10 RHEU10C | 10,000 | 115 230 | 1.32 0.66 | 333/565.83 | 1.5/13.04 1.5/6.52 | 12.50/318 ⁽²⁾ | 14.25/362 | 13.75/349 | 22.00/9.98 |
| RHEU12 RHEU12C | 12,000 | 115 230 | 1.12 0.56 | 400/697.68 | 2.0/17.39 2.0/8.70 | 12.50/318 ⁽²⁾ | 14.25/362 | 14.50/368 | 23.00/10.43 |
| RHEU16 RHEU16C | 16,000 | 115 230 | 2.52 1.15 | 533/905.67 | 2.0/17.39 3.0/13.04 | 13.50/343 | 16.00/406 | 14.75/375 | 30.00/13.61 |
| RHEU24C ⁽³⁾ RHEU24C | 24,000 | 230 | 1.64 | 800/1359.40 | 2.0/8.70 3.0/13.04 | 18.75/476 | 19.75/502 | 15.50/394 | 40.00/18.14 |
| REU20C | 20,000 | 230 | 1.64 | 667/1133.40 | N/A | 18.75/476 | 19.75/502 | 12.75/324 | 35.00/15.88 |
| REU24C | 24,000 | 230 | 1.64 | 800/1359.40 | N/A | 18.75/476 | 19.75/502 | 12.75/324 | 35.00/15.88 |
| REU30C | 30,000 | 230 | 3.05 | 1000/1699.20 | N/A | 20.50/521 | 20.75/527 | 15.00/381 | 43.00/19.50 |
| RE36 RE36C | 36,000 | 115 230 | 8.00 4.00 | 1200/2039.00 | N/A | 20.50/521 | 20.75/527 | 17.75/451 | 42.00/19.05 |

Notes:

- ⁽¹⁾ Heights shown do not include blower rings.
- ⁽²⁾ With blower in vertical position, actual height is 13.00 in. (330 mm) — not including blower ring.
- ⁽³⁾ RHEU24C models are identical except for the variation in built-in electric heat.
- Hose adapter height = 2.09 in. (53 mm) additional to height of blower outlet

| Interpreting Model Numbers | | | | | |
|----------------------------|--------------------------------|------------|---------------------------|---------------|-----------------------|
| R | H | E | U | X | C |
| Remote (Split) | No H: No Heat H: Elec. Heat | Evaporator | PSC internal blower motor | x1,000 BTU/hr | No C: 115V C: 230V |

| Capacity (BTU/hr.) | Minimum Grille Sizes (sq. in/cm) | | Minimum Duct (in/mm) |
|--------------------|----------------------------------|-----------|----------------------|
| | Return | Discharge | |
| 7,000 | 80/516 | 45/290 | 5/127 |
| 8,000 | 89/574 | 47/303 | 5/127 |
| 10,000 | 100/645 | 60/387 | 6/152 |
| 12,000 | 130/839 | 70/452 | 6/152 |
| 16,000 | 160/1032 | 80/516 | 7/178 |
| 20,000 | 200/1290 | 110/710 | 9/229 |
| 24,000 | 240/1548 | 140/903 | 9/229 |
| 30,000 | 350/2258 | 170/1097 | 10/254 |
| 36,000 | 360/2323 | 196/1265 | 10/254 |

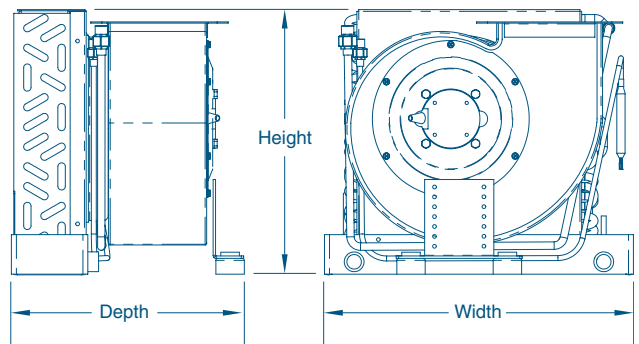

DOMETIC MARINE DIVISION

2000 N. Andrews Ave. Ext. I Pompano Beach, FL 33069 USA | 954-973-2477 | Fax 954-979-4414
www.DometicUSA.com | MarineSales@DometicUSA.com

24/7 Tech Support for United States & Canada:

8:00 AM to 5:00 PM Eastern Time: 800-542-2477
After hours and weekends: 888-440-4494

International Sales & Service:

Europe & the Middle East: Call +44(0)870-330-6101
For all other areas visit our website to find your nearest distributor.



Environmentally Responsible

Dealer: