

Passport I/O Cabin Control

Easy-To-Use Keypad/Display for Marine Air Systems



The Passport I/O Environmental Control Unit is a microprocessor based controller, designed for the precise control and monitoring of direct expansion and chilled water boat air conditioning systems from Marine Air. The control is dual voltage, operating at both 115 and 230 Volts, 50/60 Hz. The display is available in both black and white. In chilled water air handlers, the control is referred to as AH-Passport I/O.

The assembly has a ground shield to protect against static interference and RF noise. The circuit board is conformally coated to provide high resistance to external damage or corrosion.

A display cable with gold plated phone-type modular jacks connects the panel to the system controller. An optional air sensor cable is connected to the circuit board in the same manner. Non-volatile memory stores all user-selectable parameters indefinitely during operation or any power failure situations.

Internal self-diagnostic programs provide complete electronic checks of all lights, sensors, keys and circuits. Fused circuits and M.O.V.s (metal oxide varistors) provide component and board protection.

The Passport I/O control meets or exceeds applicable ABYC, U.S. Coast Guard Regulations and CE Directives.

Key Benefits

- Automatic humidity control reduces moisture when the boat is unattended.
- Cool-only, heat-only, dehumidify, and automatic mode selection.
- New optional electric-heat relay.
- Automatic or manual fan-speed selection.
- Cycle fan with compressor or continuous fan operation.
- Calibration of fan-speed settings and temp display for precise control.
- Controls shaded pole and split capacitor fan motors.
- Compressor fail-safe protection.
- Programmable de-icing cycle.
- Built-in air sensor.
- Optional remote air sensor.
- Dimmable display.
- Low voltage for optimum safety.

Specifications for Passport I/O Cabin Control

Model	Passport Compact
Voltage (V)	115/230
Cycle (Hz)	50/60
Compressor Output (V) ⁽¹⁾⁽²⁾	40
R.V. Output (V) ⁽³⁾	0.25
Fan Output (V)	6
Heater Output (V)	30/20
Pump Output ⁽²⁾	1/4 1/2
Set Point Temp. Range (°F/°C)	65-85/18.4-29.5
Display Temp. Range (°F/°C)	5-150/-15-65.6
Air Sensor Temp. Range (°F/°C)	5-150/-15-65.6
Sensor Accuracy (°F/°C)	2/77/-16/725
Water Inlet Sensor Cable Length (AH-Elite) (ft/m)	7/3
Display Cable Length (ft/m) ⁽⁴⁾	10/3.1-75/22.9
Optional Alternate/Remote Air Cable Length (ft/m) ⁽⁴⁾	7-60/2.2-18.3
Optional Outside Air Sensor Cable Length (ft/m) ⁽⁴⁾	7-50/2.2-15.3
Optional Pump Sentry Cable Length (ft/m)	7-60/2.2-18.3
Water Inlet Sensor Cable Length (AH-Elite) (ft/m)	7-60/3-19
Height (in/mm)	2.5/64
Width (in/mm)	3.19/82
Depth (in/mm)	0.94/24
Panel Cut-Out Height (in/mm)	1.875/48
Panel Cut-Out Width (in/mm)	2.5/64

1 Maximum loads should not exceed 85% of listed output ratings.
 2 Does not apply to AH-Passport I/O.
 3 Used as water valve output in AH-Passport I/O mode.
 4 Maximum length 67.5 ft. (23 m).
 5 Bezeled sold separately, dimensions may vary depending on style.

Dimensions

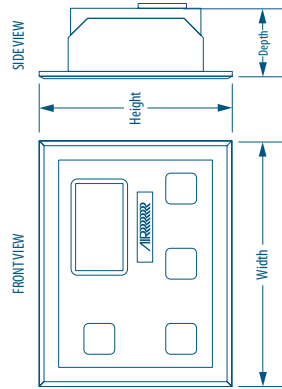

Installation

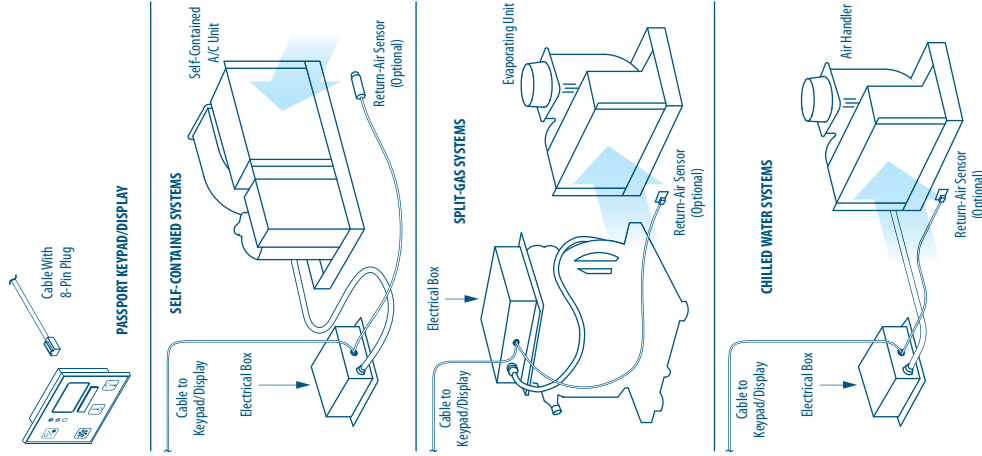

PASSPORT KEYPAD/DISPLAY

SELF-CONTAINED SYSTEMS

SPLIT-GAS SYSTEMS

CHILLED WATER SYSTEMS

Dealer



DOMETIC MARINE DIVISION
 2000 N. Andrews Ave. | Pompano Beach, FL 33069 USA | Tel. 954-973-2477 | Fax: 954-979-4414
 www.Domestic.com/Marine | MarineSales@DomesticUSA.com

24/7 TECH SUPPORT FOR UNITED STATES & CANADA:
 8:00 AM to 5:00 PM Eastern Time: 800-542-2477
 After hours and weekends: 888-440-4494

INTERNATIONAL SALES & SERVICES
 Europe & the Middle East: Call +44(0)870-330-6101
 For all other areas visit our website to find your nearest distributor.

L-2630 Rev. 20120824

Specifications and availability subject to change without notice.