

SMX Series Control Systems (DX)

◆ INSTALLATION

English

For Direct Expansion Systems Using:

SMX II
SMXOnline^{NET}

Cruisair[®]
DIRECT EXPANSION SYSTEMS

Taylor Made Environmental, Inc.
P.O. Box 15299 • Richmond, Virginia 23227-0699 • USA
Telephone: 804-746-1313 • Facsimile: 804-746-7248
E-mail: sales@tmenviro-va.com
www.tmenviro.com

Revised: 10-25-01
L-0503

For LP-25

SMX Series Parts List

Part	SMX II	New SMXII HV <small>(All SMX II StowAways H99 and later)</small>	SMX Net	New SMX Net <small>(All Net units B00 and later)</small>
Display	SMXIIAB	SMXIIAB	SMXLB	SMXLB
Cover Plate	PXB, N, W, G	PXB, N, W, G	PNB, N, W, G	PNB, N, W, G
Power Logic Box	PLPX N/A N/A N/A	PLSX (Replaces SX7-24CK) PLRX (Replaces SXR10-16CK) PLRX7 (Replaces SXR7 & 7C) PLRX7CK (Replaces SXR7CK)	NPLPX N/A N/A N/A	NPLPX N/A N/A N/A
Upgrade WFAH/F	A-285	A-284	NPLRX-3	NPLRX-3
Upgrade FX/SX	N/A	N/A	NPLRX-2	NPLRX-2
Upgrade TW Air Handler	PLTX	PLTX-HV	NPLTX	NPLTX
P/L Board	A-281C or T	A-288C or T	A-282NC or T (TW)	A-282NC or T (TW)
EPROM	A-280C	N/A	4220960 or 62(TW)	4220970 or 72(TW)
Display Cable	CX**	CX**, (CXP** Aug 2000)	CX**	CX**, (CXP** Aug 2000)
CX to RJ11 Adapter	N/A	4163805	N/A	4163805
Temperature Sensor	TSE**	TSEP**	TSE**	TSEP**
TSE to RJ11 Adapter	N/A	4163804	N/A	4163804
Net Cable	N/A	N/A	CN**	CNP**
CN to RJ11 Adapter OUT	N/A	N/A	N/A	4163808 (Yellow OUT)
CN to RJ11 Adapter IN	N/A	N/A	N/A	4163807 (Blue IN)
Convenience Cable	N/A	N/A	CC*	CC*
Convenience Panel	N/A	N/A	SMXCB	SMXCB
Convenience Cover	N/A	N/A	PCB, N, W, G	PCB, N, W, G

SMX Systems Retrofit Parts

MODEL	SMX System	Description
A-285	SMX II	Retrofit kit for 3-knob switch systems (not SH) 115V/230V
NPLRX-3	SMX Net	Retrofit kit for 3-knob switch systems (not SH) 115V/230V
NPLRX-2	SMX Net	Retrofit kit for SX, SH, FX units 115V/230V
HNRX	SMX Net	Auxiliary heat kit for all Net retrofit kits
A-201	ALL	Low pressure switch, screw on
A-204	ALL	Low pressure switch port kit, weld in
4240100	ALL	Low pressure switch Tee adaptor, for SH units

Retrofit kits include Power/Logic box, wiring harness with plug or terminal strip, and instructions.

To retrofit SMX II to SH Stowaway units, use PLPX or PLPLC replacement P/L boxes.

SMX Control System Components

SMX II	SMX Net	Description
SMXIIB	SMXLB	Control, Black membrane, Separate snap-on plate
SMXIIN	SMXLN	Control, Brown membrane, Separate snap-on plate
SMXIIBB	N/A	Control, Black membrane w/ no copy, Separate snap-on plate
SMXIIBN	N/A	Control, Brown membrane w/ no copy, Separate snap-on plate
PXB	PNB	Plate, Snap-on black plastic
PXN	PNN	Plate, Snap-on brown plastic
PXG	PNG	Plate, Snap-on beige plastic
PXW	PNW	Plate, Snap-on white plastic
PLP(FX-SX)	NPLP(FN-SN)	Power/Logic module for 115V
PLPLC(FX-SX)	NPLPC(FN-SN)	Power/Logic module for 230V
PLPLC		Power/Logic replacement module for 230V, SX24C only
A-281C	A-282NC	Replacement Power/Logic board
N/A	SMXCB	Convenience Panel, Black
N/A	SMXCN	Convenience Panel, Brown
N/A	CC##(length)	Convenience Panel ribbon
N/A	PCB	Plate, Snap-on black plastic
N/A	PCN	Plate, Snap-on brown plastic
N/A	PCG	Plate, Snap-on beige plastic
N/A	PCW	Plate, Snap-on white plastic
50759-00	50759-00	Wall mount thermistor cover, stainless
50759-01	50759-01	Wall mount thermistor cover, white
50759-02	50759-02	Wall mount thermistor cover, black
50759-03	50759-03	Wall mount thermistor cover, brown

Components Common to All SMX Control Systems

TSE2	Temperature sensing element	2 ft. long w/ plug			
TSE5	Temperature sensing element	5 ft. long w/ plug	CX5	Plug in cord	5 ft. long
TSE10	Temperature sensing element	10 ft. long w/ plug	CX10	Plug in cord	10 ft. long
TSE15	Temperature sensing element	15 ft. long w/ plug	CX15	Plug in cord	15 ft. long
TSE20	Temperature sensing element	20 ft. long w/ plug	CX20	Plug in cord	20 ft. long
TSE30	Temperature sensing element	30 ft. long w/ plug	CX30	Plug in cord	30 ft. long
TSE 40	Temperature sensing element	40 ft. long w/ plug	CX40	Plug in cord	40 ft. long
TSE 60	Temperature sensing element	60 ft. long w/ plug	CX60	Plug in cord	60 ft. long
TSE 80	Temperature sensing element	80 ft. long w/ plug	CX80	Plug in cord	80 ft. long

Retrofit Components for SMX Control Systems

Existing System	Existing Control	SMX II Components	SMX Net Components
WF-WJ StowAway I-III	SA3-Z & DSZ3-Z SMX (PM1 & 1C) series controls (SMXII variable fan speed only, others will support 2 speed units)	A-285 SMXIIA? (B,N) PX? (B,N,W,G) CX## (length) TSE## (length) A-201 A-204	NPLRX-3 (115-230V) SMXL? (B,N) PN? (B,N,W,G) CX## (length) 2) TSE## (length) A-201 A-204
WF-WJ StowAway I-III	SA3-Z & DSA3-Z series controls previously retrofitted to SMXII control	Does Not Apply	NPLRX-3 (115-230V) SMXL? (B,N) PN? (B,N,W,G) CN## (length) 2) TSE## (length)
WF-WJ (20,000 through 48,000 BTU system)	SA3-B & SMX (PM2C) series controls with 2 speed blowers on evaporators	Does Not Apply	NPLRX-3 (115-230V) SMXL? (B,N) PN? (B,N,W,G) CX## (length) CN## (length) 2) TSE## (length) A-201 A-204
StowAway V series (SH)	SA3-Z series control	PLP (115V) or PLPC (230V) SMXIIA? (B,N) PX? (B,N,W,G) CX## (length) TSE5 A-201 42401-00	NPLRX-2 (115-230V) SMXL? (B,N) PN? (B,N,W,G) CX## (length) CN## (length) TSE5 TSE## (length) A-201 42401-00
StowAway V series (SX)	SMXII series control	Does Not Apply	NPLRX-2 (115-230V) SMXL? (B,N) PN? (B,N,W,G) CN## (length) 1) TSE## (length)
FS	SMX series control	A-285 SMXIIA? (B,N) PX? (B,N,W,G) CX## (length) TSE## (length)	NPLRX-3 (115-230V) SMXL? (B,N) PN? (B,N,W,G) CX## (length) CN## (length) 2) TSE## (length)
HNRX	SMX Net Auxiliary heat kit for all Net retrofit kits		

SMX II and SMX Net Controls • Installation

Installing the SMX Keyboard Control

To be operated satisfactorily, the SMX keyboard control must be installed so it is both visible and accessible. It should be placed in plain view and within easy reach of the operator. Overhead locations are discouraged since they make it very difficult to use the SMX control. In staterooms, the control should be installed so it is visible, and if possible, accessible from the bed.

Select a spot on a vertical surface, this can be an inside or outside wall, partition or other permanent structure with rear access for wiring. The SMX control operates on low voltage DC and is certified ignition-protected. The space behind the SMX control does not have to be ventilated since the control components do not produce any heat.

The cutout dimensions for the SMX II & SMX Net are 2.625 (2-5/8) x 7.25 (7-1/4) inches plus or minus .063 (1/16) inch. The control plate size is 3.063 (3-1/16) x 7.75 (7-3/4) inches.

After cutting the hole for the keyboard control, make sure it fits and the printed circuit board is clear of the bulkhead and that no objects of any kind are in a position to contact the SMX circuitry. Plug the interconnect cable in and route it to the Power/Logic relay. Refit the control in the hole and secure it with four No. 6 x 3/8 inch screws. Hook the decorative plastic cover at the top, press it flat from the top down, and snap it in place at the bottom.

Installing the Power/Logic Relay

The SMX Power/Logic relay is ignition protected, enclosed, and operates in ambient temperatures up to 130°F. Their relays dissipate heat when operating, and so must be installed in a well-ventilated location. The power relay is NOT waterproof and must be placed where it will NOT get wet. The relay may be installed in any position, although a vertical surface is best since this allows the heat generated by the triacs to rise naturally. In selecting a location for the Power/Logic relay, bear in mind that several sets of wires will be connected to it. Refer to installation diagrams in this packet.

Installing the TSE

Inside Temperature Thermistor

The TSE** inside thermistor is the device which measures the inside air temperature. This is the input data needed by the SMX to control the system. The sensor is the 1 inch long by 5/16 inch diameter device at the end of the two conductor shielded cable with a plug at the opposite end. For best results, the sensor should be placed in the system return air duct, but as far away from the system evaporator coil as possible. The best location is usually directly behind the return air grill. Under no circumstances should the thermistor touch the system evaporator or be placed in the system discharge air. If the thermistor is placed in the return air, use the preprogrammed mode of continuous fan operation. If intermittent fan operation is desired, where the fan cycles with the compressor, program accordingly

(see owner's manual), and move the thermistor to be wall mounted on an INSIDE surface, not subject to any influence from heat outside of the area. If the thermistor is wall mounted, there are four different color thermistor covers available from Cruisair. See SMX component list for the thermistor model numbers. The TSE is plugged into the three pin header marked "Inside TSE". If there is any excess wire, the plug can be cut off and the wires connected to the power relay at the two tab terminals marked "Inside Temp". If there is not enough wire, the leads may be extended up to 100 feet by using an AWG 18 shielded pair of wires. If a shielded pair is used, GROUND THE SHIELD TO THE GROUND POST INSIDE THE RELAY. The other end should not be grounded. Secure these wires per low DC voltage standards.

Connecting Control Keyboard To Power Relay Using SMX Interconnect Cable

We recommend using TME model number CX series interconnect cable, which is a shielded, three conductor, color coded cable, with plugs on both ends. This cable is available in lengths of 10, 15, 20, 30, 40, 60, and 80 feet. See component list for complete model numbers. Route this cable, which will carry low voltage DC, from power relay to the keyboard control. Plug the cable in at both ends. The plugs are polarized and will engage easily if positioned properly. Also note that the plugs on each end of the cable are identical. Secure this cable per low DC voltage standards.

Connecting Control Keyboard To Power Relay Using SMX Interconnect Cable

Overview: All pressure switch connections are made at the four push-on terminals in the power relay, marked high and low pressure. While the low pressure switch is optional, the high pressure switch must be connected in all SMX installations.

High Pressure Switch: Using the high pressure switch, already installed on every Cruisair condensing unit, is appropriate. Disconnect it from its present line application and connect it to the SMX system. Remove the 2 purple wires from the switch and connect them together with a crimp type butt connector. DO NOT use a screw type wire nut. Use AWG 18 to 22 wire to connect the pressure switch to the SMX system in the Power/Logic box. Shielding or twisting is not necessary. Make the connections at the pressure switch with push-on terminals.

INCLUDED SMX CONTROL SYSTEM DIAGRAMS

SMX II

Drawing #

1. 840-00 Typical 3 knob control retrofit
2. XEC-92011 Typical 3 knob retrofit with SA4-Z slave switch
3. XEB-91012 FX & SMXII installation with one evaporator
4. XEB-91006 FX & SMXII installation with two evaporators in parallel
5. XEB-93016 FX & SMXII installation with SA4-Z slave switch
6. XEB-91011 FX & SMXII installation with SA4AZ slave switch
7. 849-00 FX20-48 (230 VAC / 3Ph) (Before May 2000)
8. XEB-96034 SX7-16 installation (Before August 1999)
9. 802-72 SX24C installation (Before August 1999)
10. 843-01 Wiring diagram combo Power/Logic box, 230V
11. 082570 SXR7-16C Wiring diagram rotary StowAways with HV board (August 1999 & Later)
12. 082577 SX7-24C Wiring diagram reciprocating StowAways with HV board (August 1999 & Later)
13. 083703 FX20-36CK Wiring diagram (May 2000 & Later)
14. 083704 FX48RC Wiring diagram (June 2000 & Later)
15. SKA-1087 Instructions on testing A-288C board.
16. P-1044 SXF 5-16 (C/CK), StowAway F with SMX II Control, 115/230 VAC
(Formerly drawing # (M1010097C) Dated: 8-10-99)

SMX Net

1. Figure 1 Explanation of SMX Net Inputs and Outputs
2. Figure 2 SMX Net Version & Programming Setup Codes
3. SKA-349 SMX software labeling
4. 825-21 FL & FN installation (5,000 - 48,000 BTU/115 & 230V)
5. 41628-04 Typical 3 knob control retrofit
6. 080298 Typical SMX II SX or FX retrofit to SMX Net
7. 083200 SMX Net installation with Convenience Panel
8. 831-02 SMX Net hub box installation with 5 systems

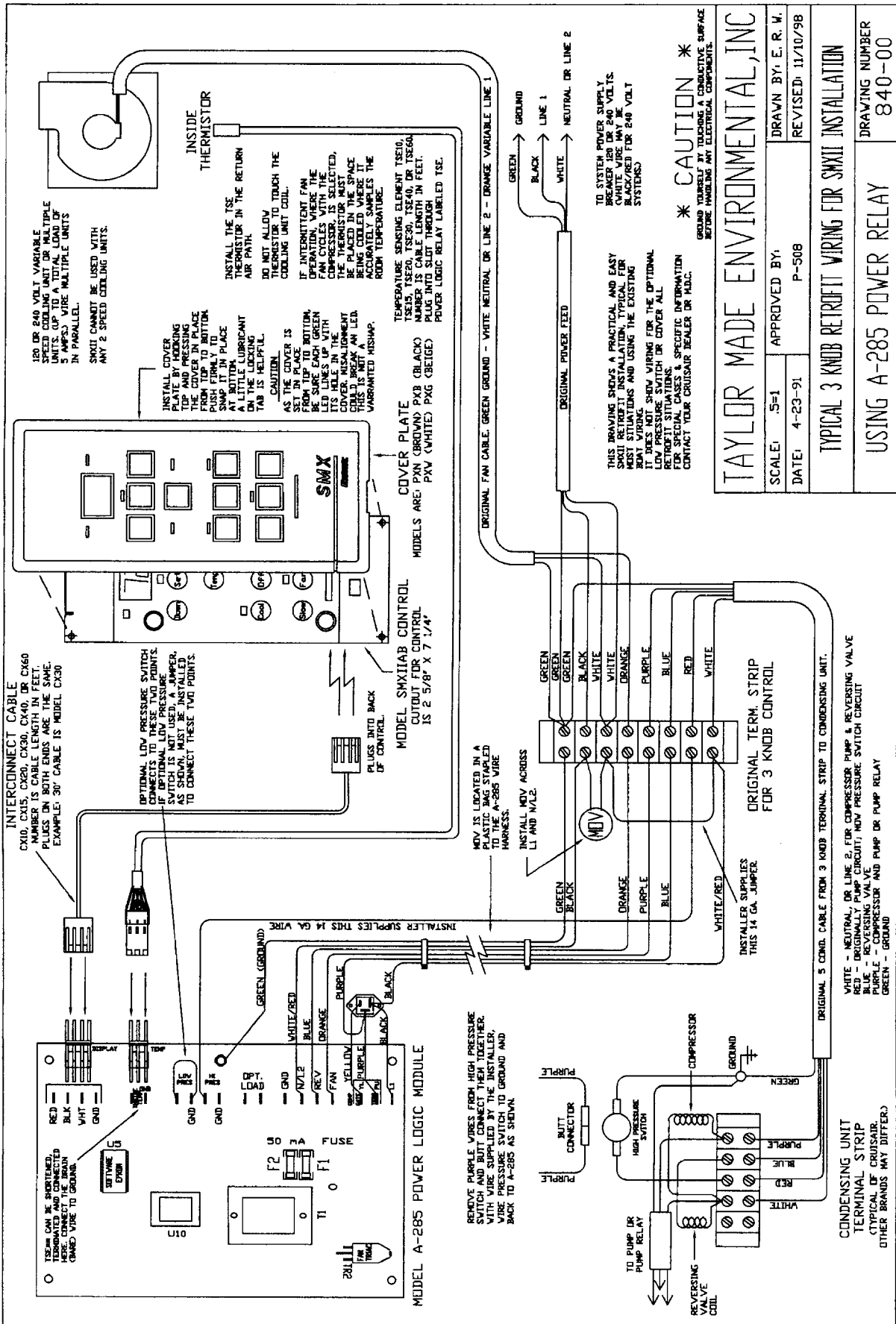

No. XEC-92011 Typical retrofit from 3 knob to SMXII

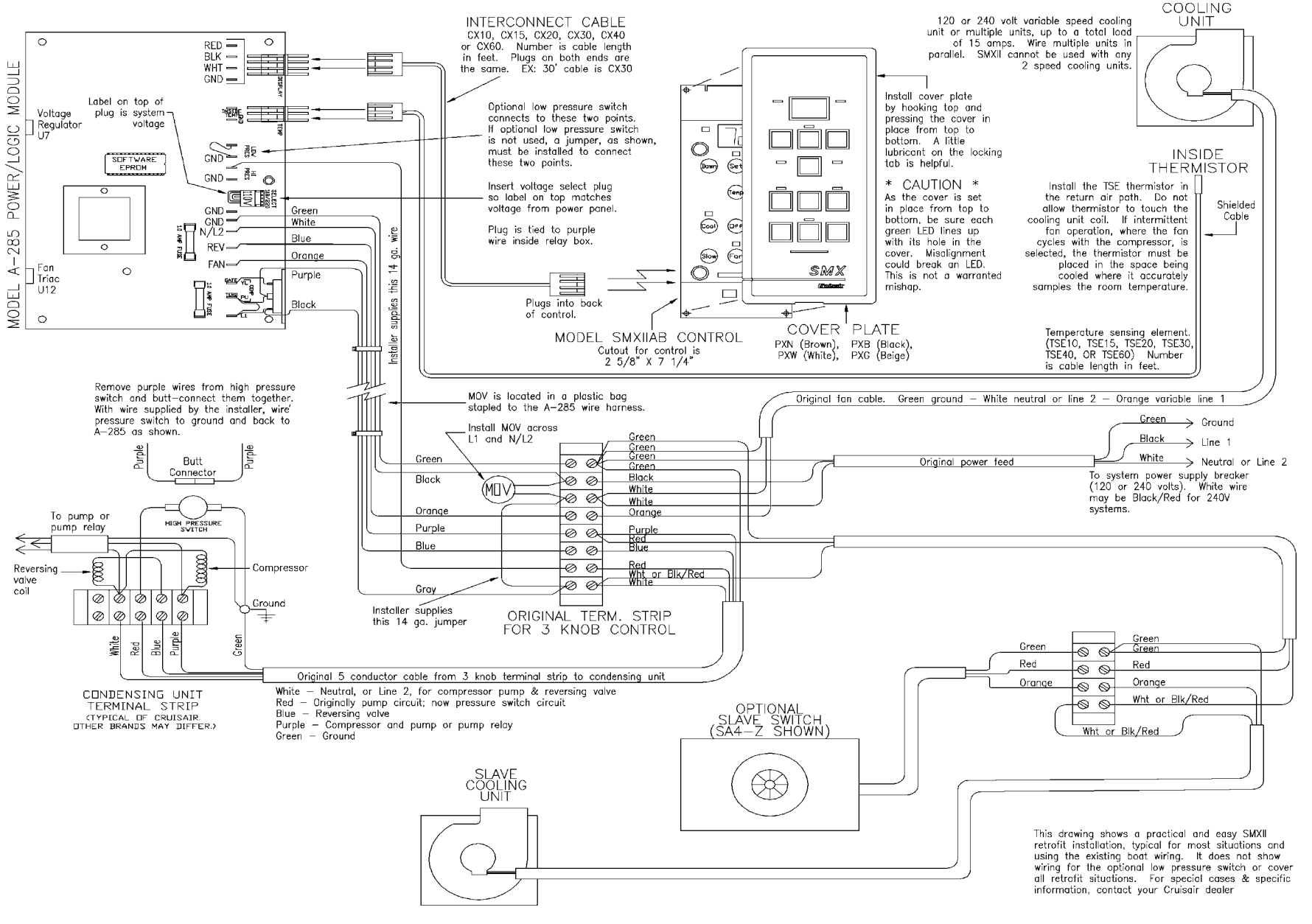

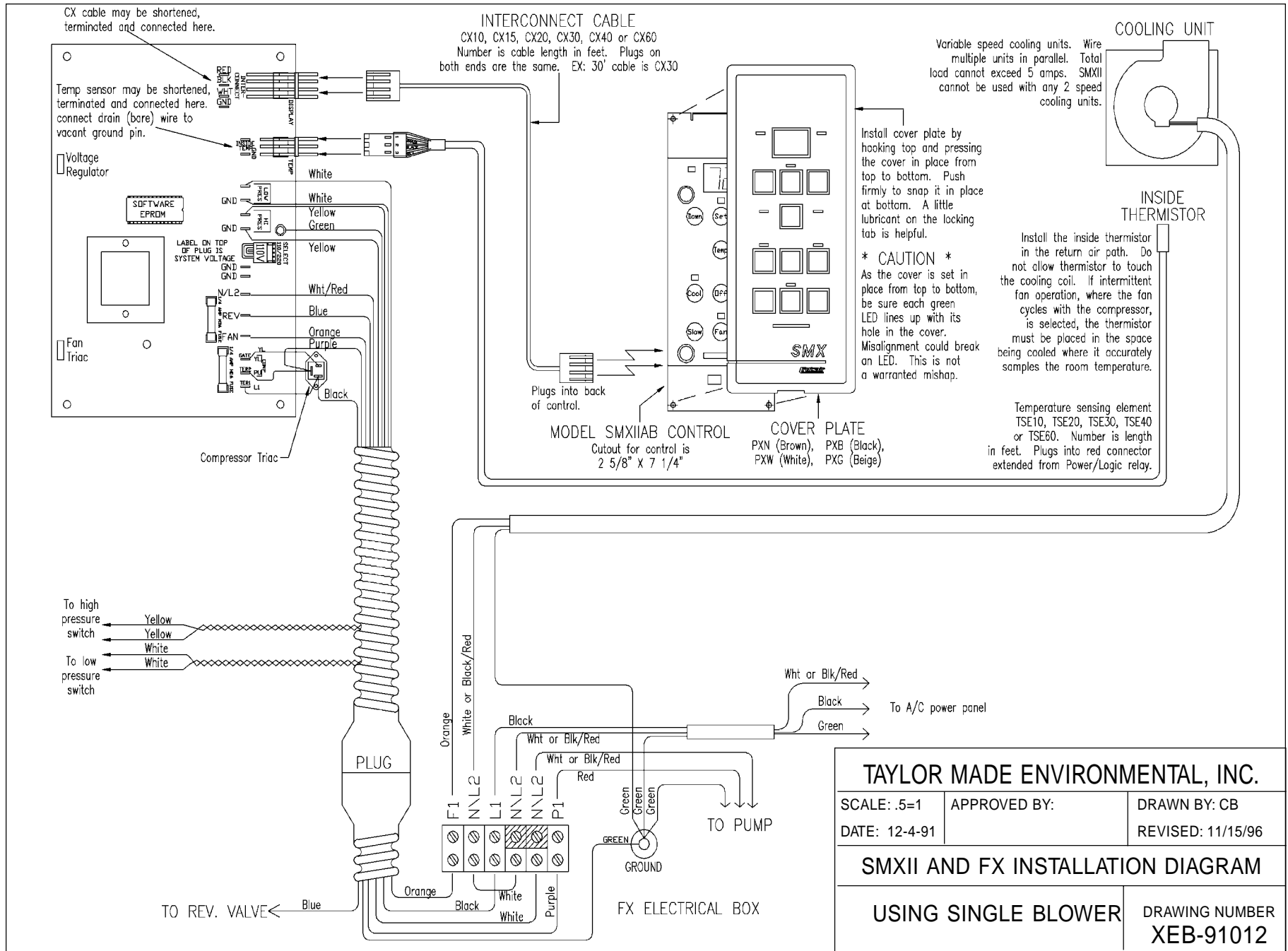

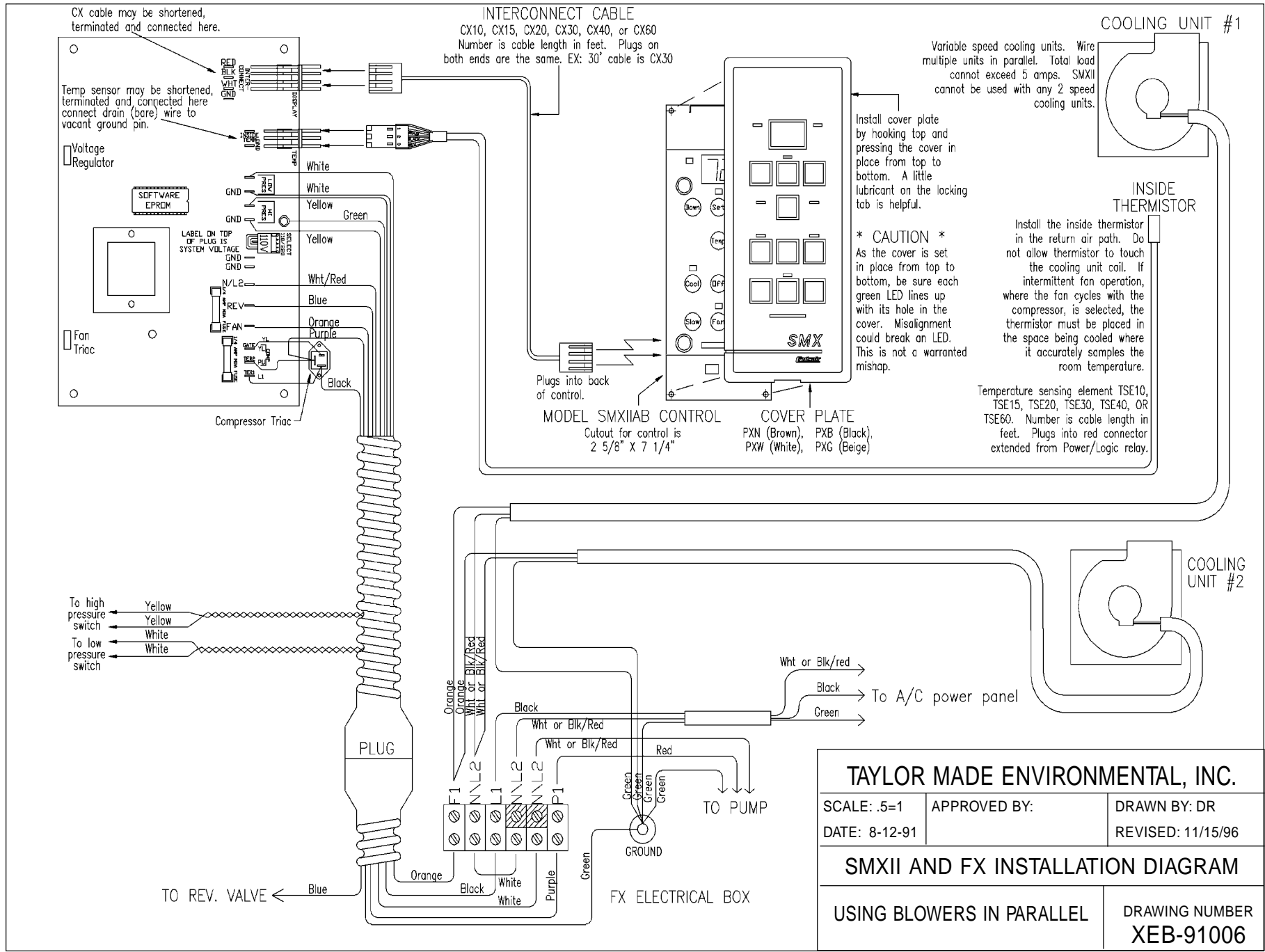

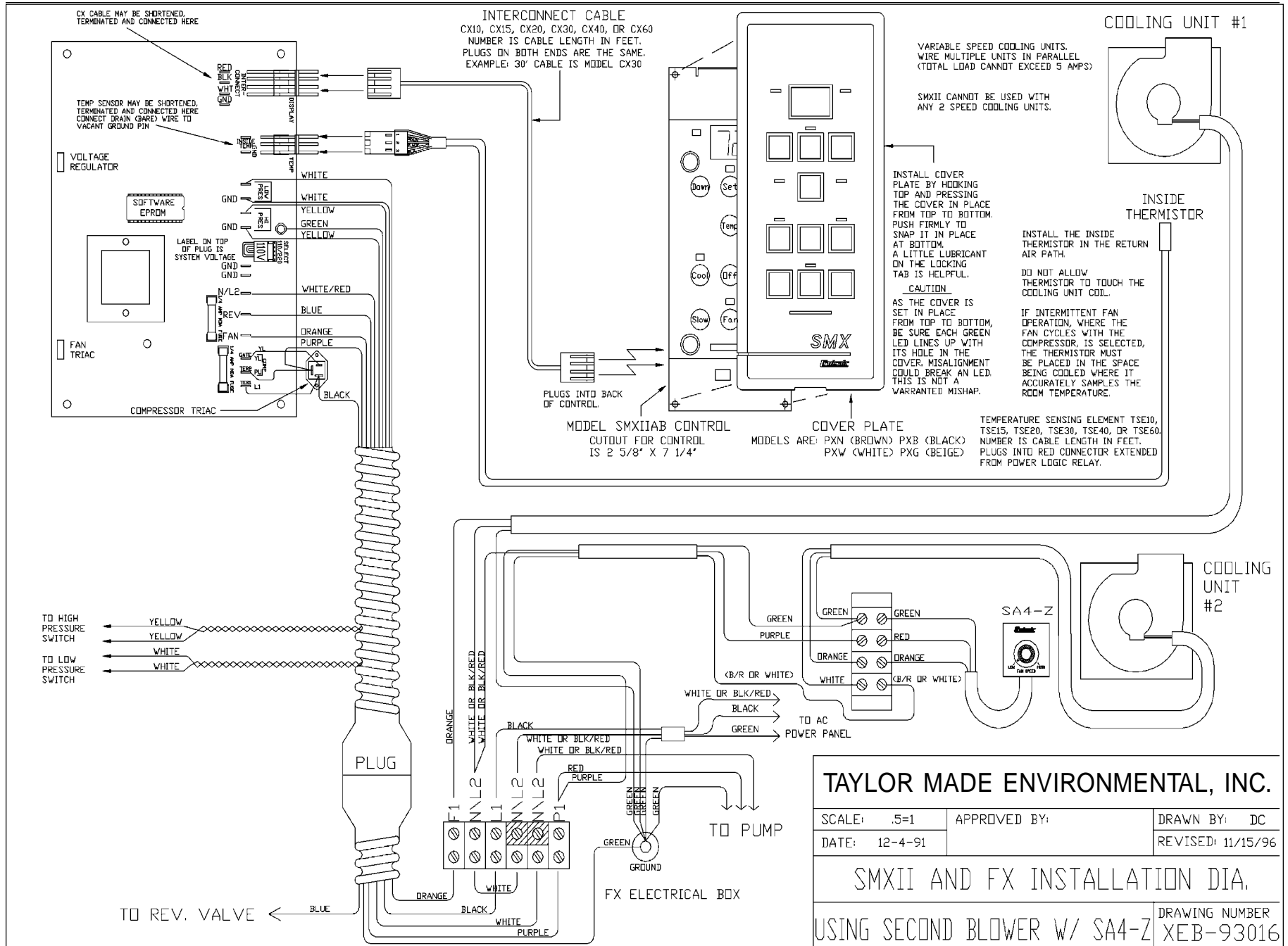

TAYLOR MADE ENVIRONMENTAL, INC.		
SCALE: .5=1	APPROVED BY:	DRAWN BY: DC
DATE: 12-4-91		REVISED: 11/15/96
SMXII AND FX INSTALLATION DIA.		
USING SECONDR BLOWER W/ SA4-Z		DRAWING NUMBER XEB-93016

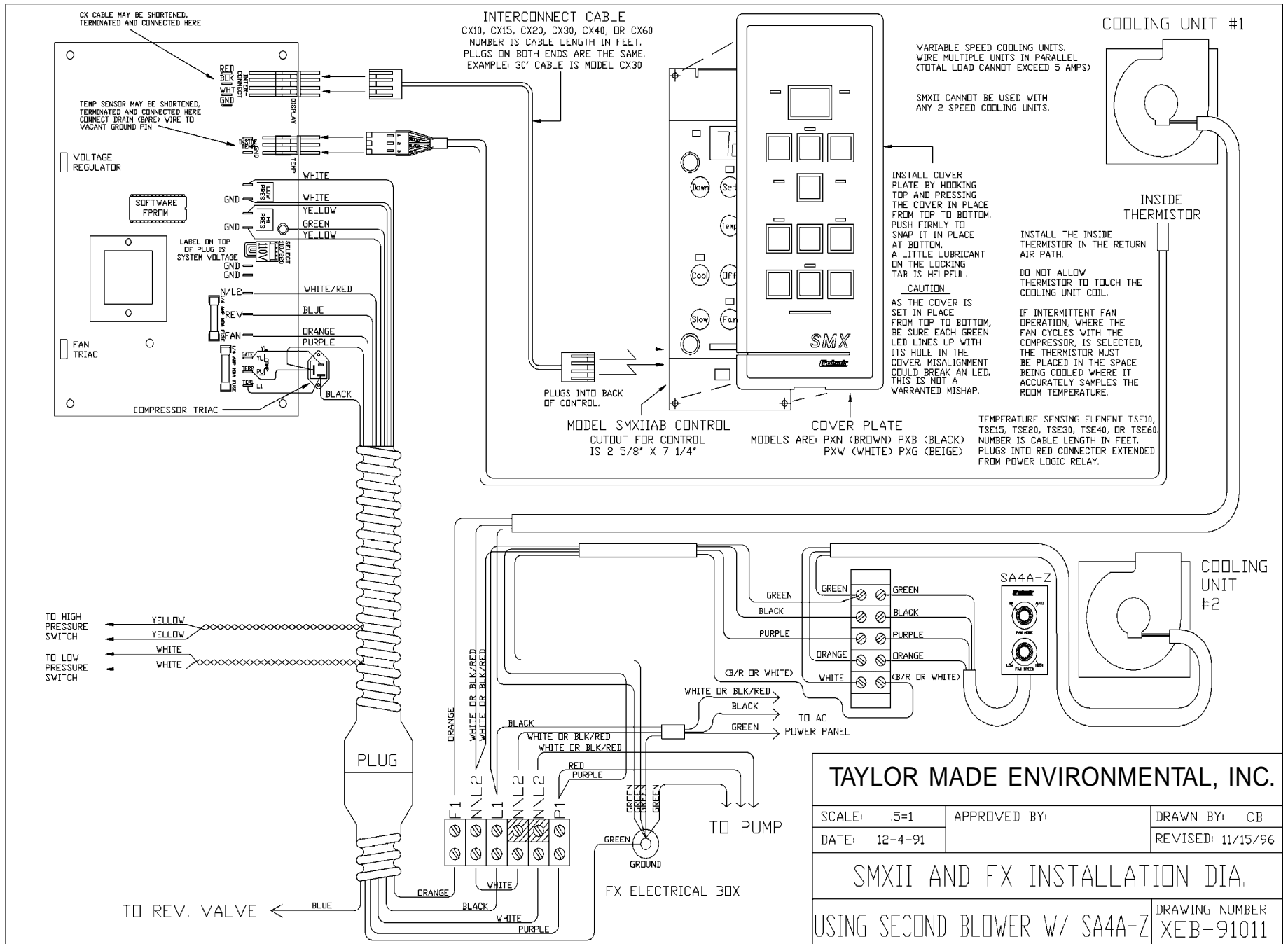

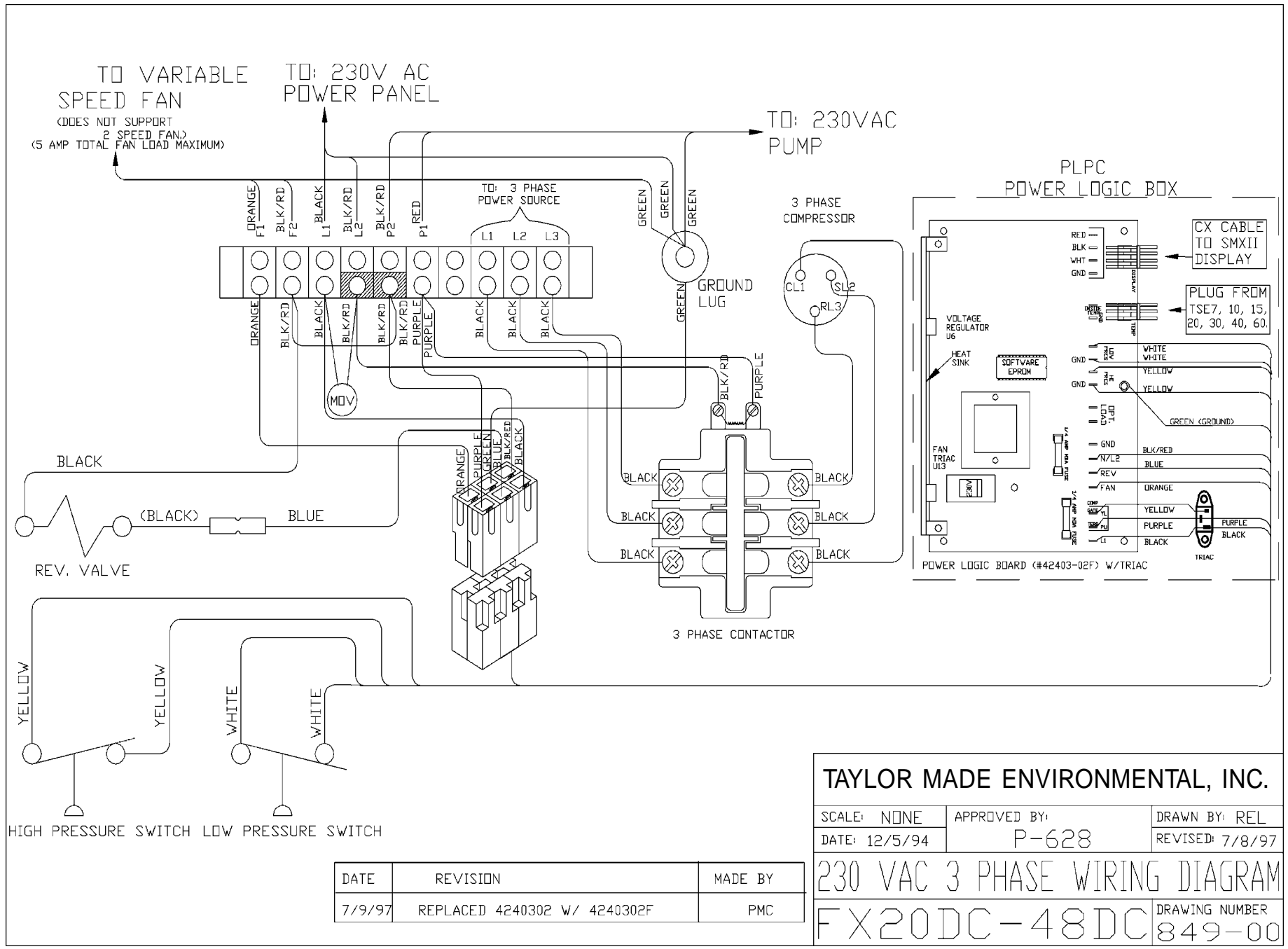

TAYLOR MADE ENVIRONMENTAL, INC.

SCALE: NONE	APPROVED BY:	DRAWN BY: REL
DATE: 12/5/94	P-628	REVISED: 7/8/97

230 VAC 3 PHASE WIRING DIAGRAM

FX20DC-48DC DRAWING NUMBER 849-00

DATE	REVISION	MADE BY
7/9/97	REPLACED 4240302 W/ 4240302F	PMC

TO POWER IN
TO PUMP

SX JUNCTION BOX

PLUG FOR CX CABLE TO SMXIIAB DISPLAY

SX CAP RELAY BOX

CX CABLE MAY BE SHORTENED, TERMINATED AND CONNECTED HERE.

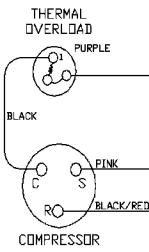
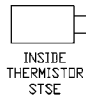
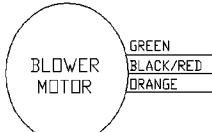
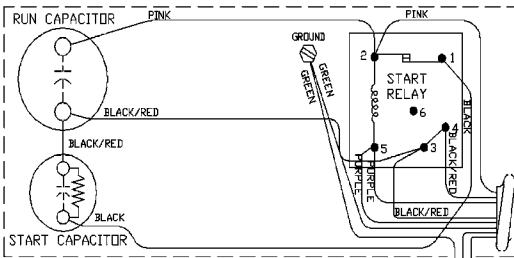

* NOTE *
THE BLACK/RED WIRE WILL BE WHITE ON 115VAC UNITS.

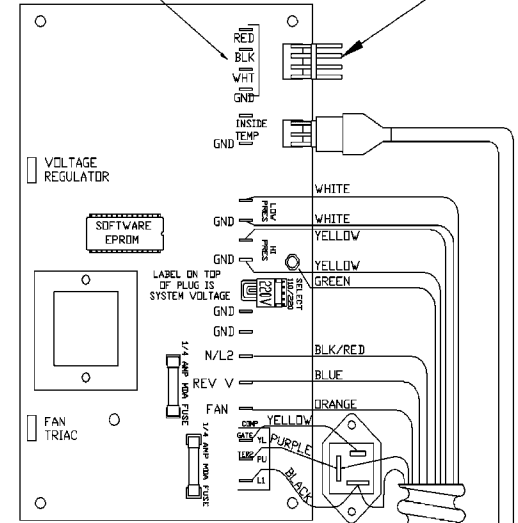
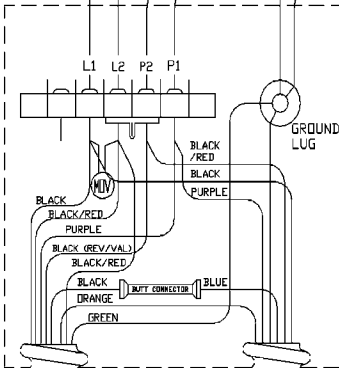
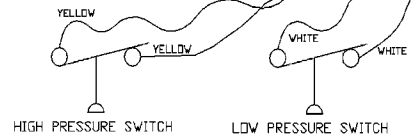

POWER LOGIC BOARD
PLP - 115VAC
PLPC - 230VAC

TAYLOR MADE ENVIRONMENTAL, INC.

SCALE: NONE	APPROVED BY:	DRAWN BY: REL
DATE: 11/15/96		REVISED: 11/21/96

SX7-16C INSTALLATION DIAGRAM

115VAC OR 230VAC	DRAWING NUMBER XEB-96034
------------------	-----------------------------

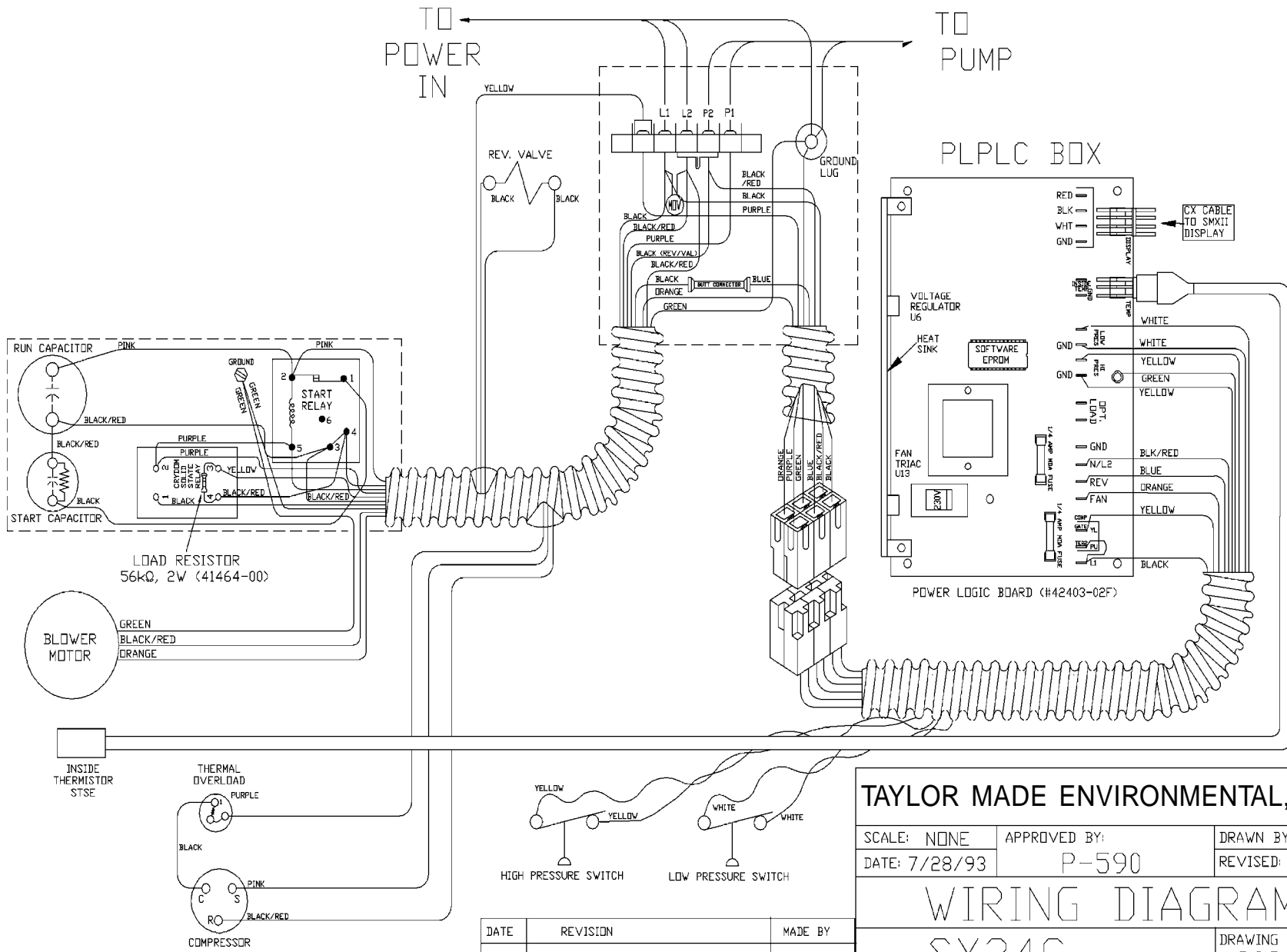

TAYLOR MADE ENVIRONMENTAL, INC.

SCALE: NONE	APPROVED BY:	DRAWN BY: DR
DATE: 7/28/93	P-590	REVISED: 7/9/97

WIRING DIAGRAM

SX24C DRAWING NUMBER
802-72

DATE	REVISION	MADE BY
7/9/97	REPLACED 4240302 W/ 4240302F	PMC

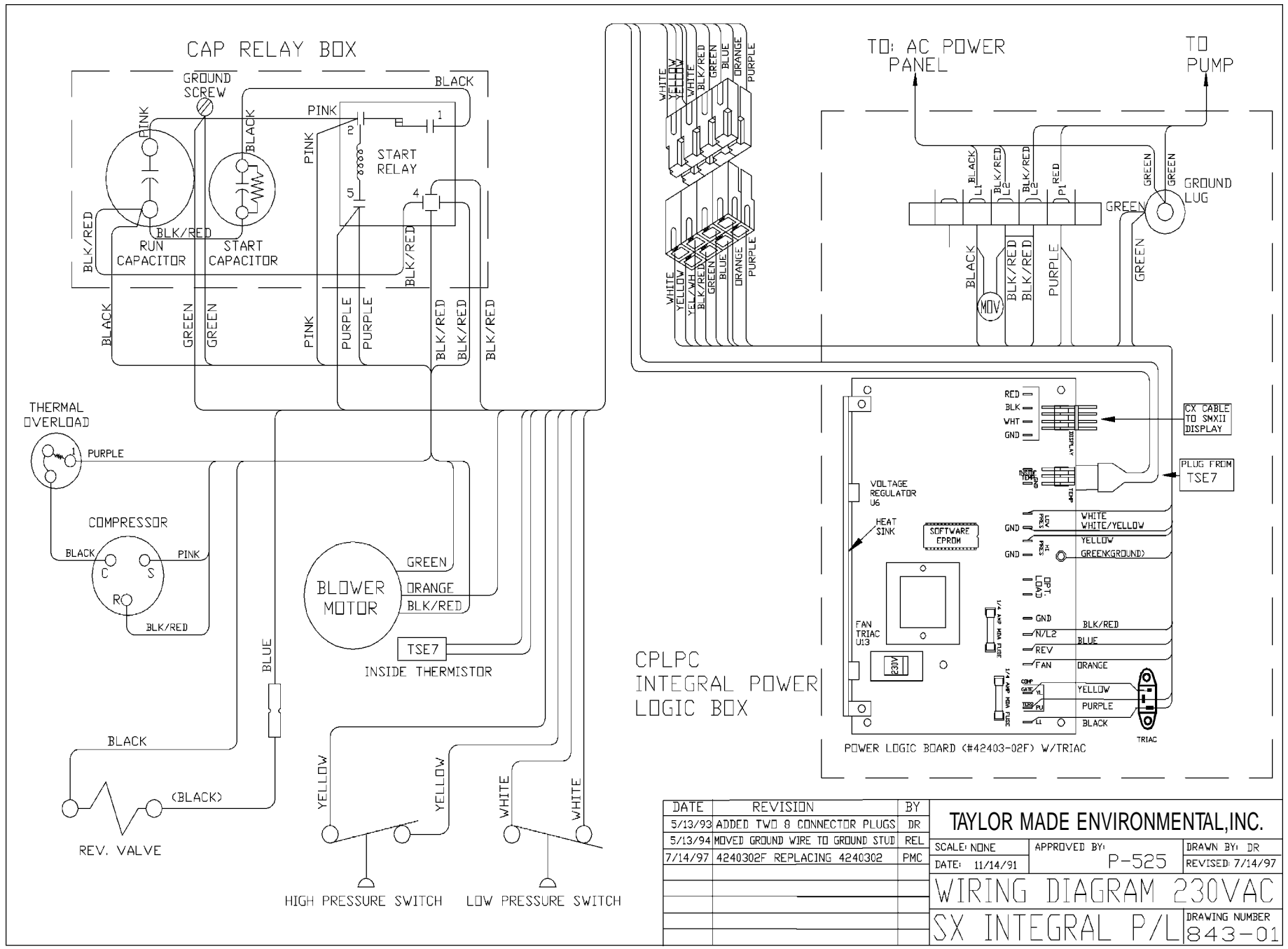

DATE	REVISION	BY	TAYLOR MADE ENVIRONMENTAL, INC.		
5/13/93	ADDED TWO 8 CONNECTOR PLUGS	DR	SCALE: NONE	APPROVED BY:	DRAWN BY: DR
5/13/94	MOVED GROUND WIRE TO GROUND STUD	REL	DATE: 11/14/91	P-525	REVISED: 7/14/97
7/14/97	4240302F REPLACING 4240302	PMC	WIRING DIAGRAM 230VAC		
			SX INTEGRAL P/L DRAWING NUMBER 843-01		

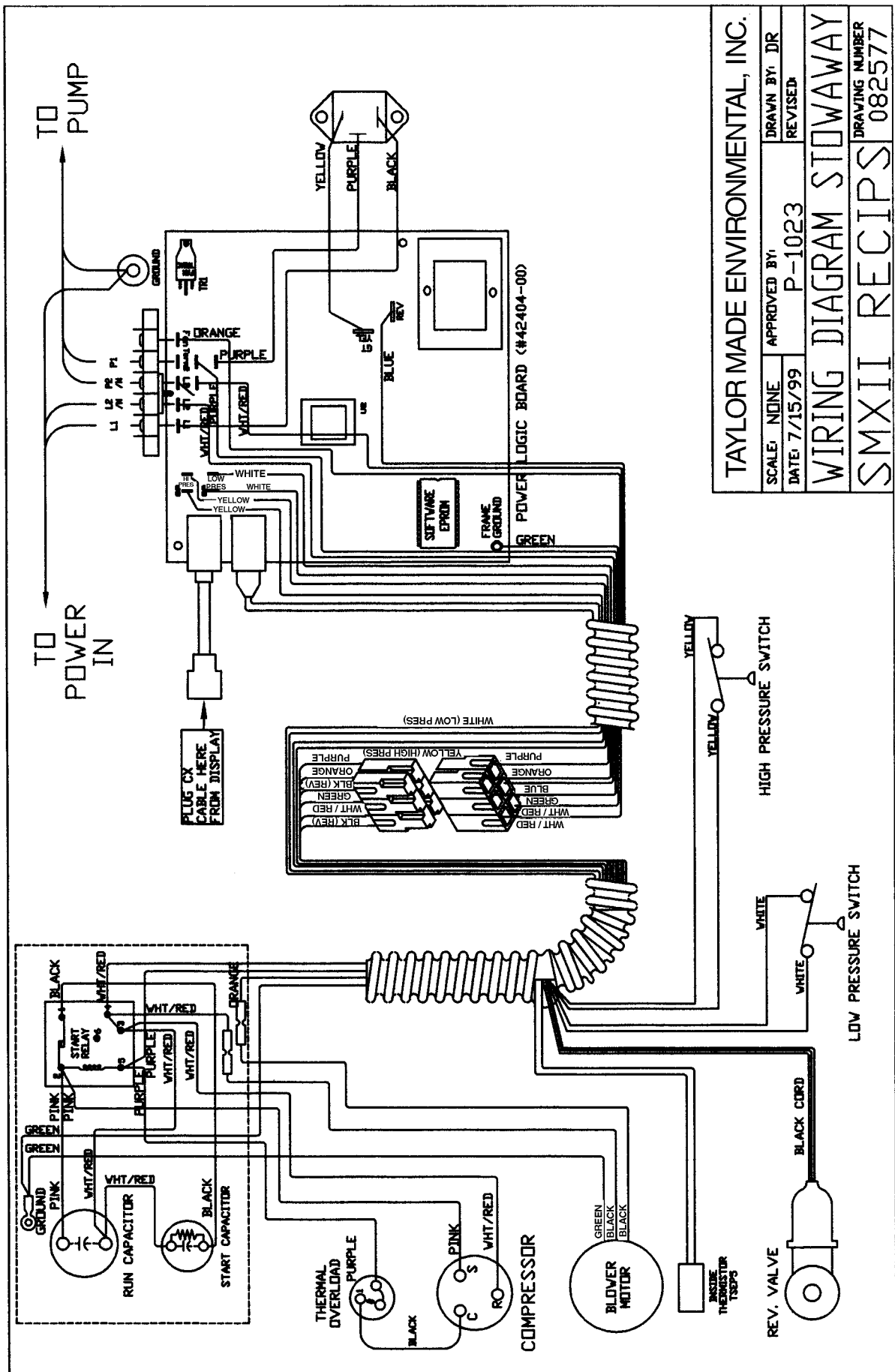

TAYLOR MADE ENVIRONMENTAL, INC.
 SCALE: NONE APPROVED BY: DRAWN BY: DR
 DATE: 7/15/99 P-1023 REVISED
 WIRING DIAGRAM STOWAWAY
 SMXII RECIPS DRAWING NUMBER 082577

TEST ORDER PROCEDURE (CAUTION: ALWAYS TURN OFF BREAKER TO UNIT BEFORE SERVICING.)

1) COMPRESSOR, BLOWER & PUMP
 CONNECT JUMPER (A) ACROSS 'L1' & 'P1' AT TERMINAL STRIP TO TEST COMPRESSOR & PUMP.
 CONNECT JUMPER (A) ACROSS 'L1' & BLANK (VACANT) TERMINAL TO TEST BLOWER.

2) REV VALVE
 REMOVE BLUE WIRE FROM TAB TERMINAL 'REV' AND CONNECT TO 'L1' WITH JUMPER (B)

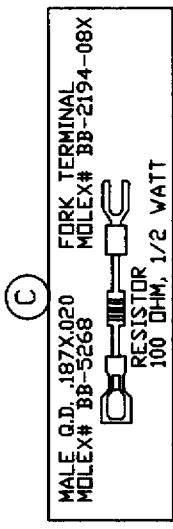
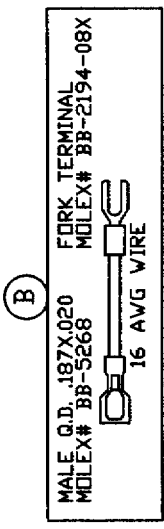
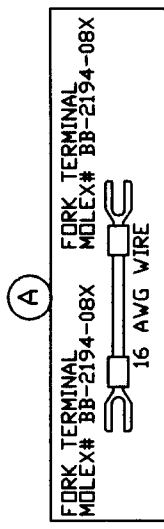

3) COMPRESSOR & PUMP
 IF COMPRESSOR RUNS EVEN IF THE OFF KEY IS PRESSED, REMOVE THE YELLOW GATE WIRE.
 IF COMPRESSOR STOPS, REPLACE A-288C BOARD. IF CONTINUES RUNNING, REPLACE A-548 TRIAC.
 IF 'COOLING' LED INDICATOR ON DISPLAY IS LIT AND COMPRESSOR DOES NOT RUN, REMOVE YELLOW GATE WIRE FROM TERMINAL 'YEL' AND CONNECT TO TERMINAL 'P1' WITH JUMPER (C) IF COMPRESSOR RUNS, REPLACE A-288C. IF COMPRESSOR DOES NOT RUN, REPLACE A-548 TRIAC.

POWER LOGIC BOARD (A-288C, 4240400)

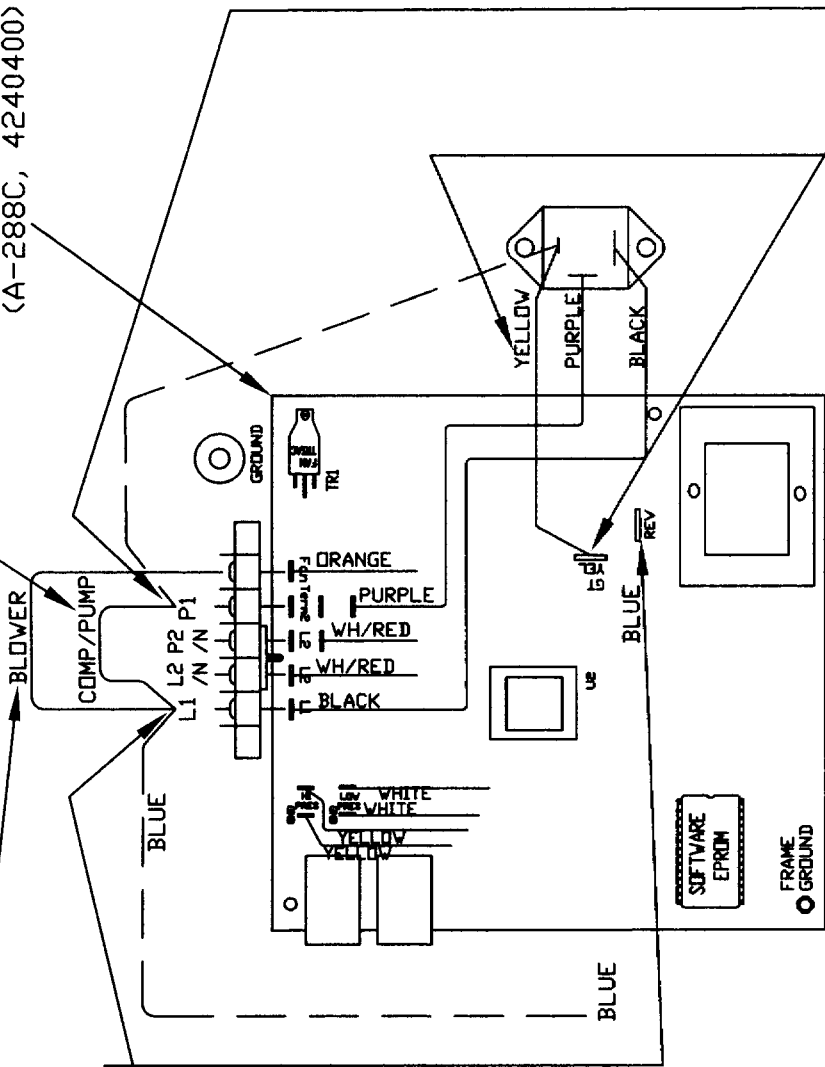

TAYLOR MADE ENVIRONMENTAL, INC. INSTRUCTIONS SERVICING SX & SXR
 W/ SMXII HV BOARD

SCALE: NONE	APPROVED BY:	DRAWING NUMBER
DATE: 7/30/99	DR. DR	SKA-1087

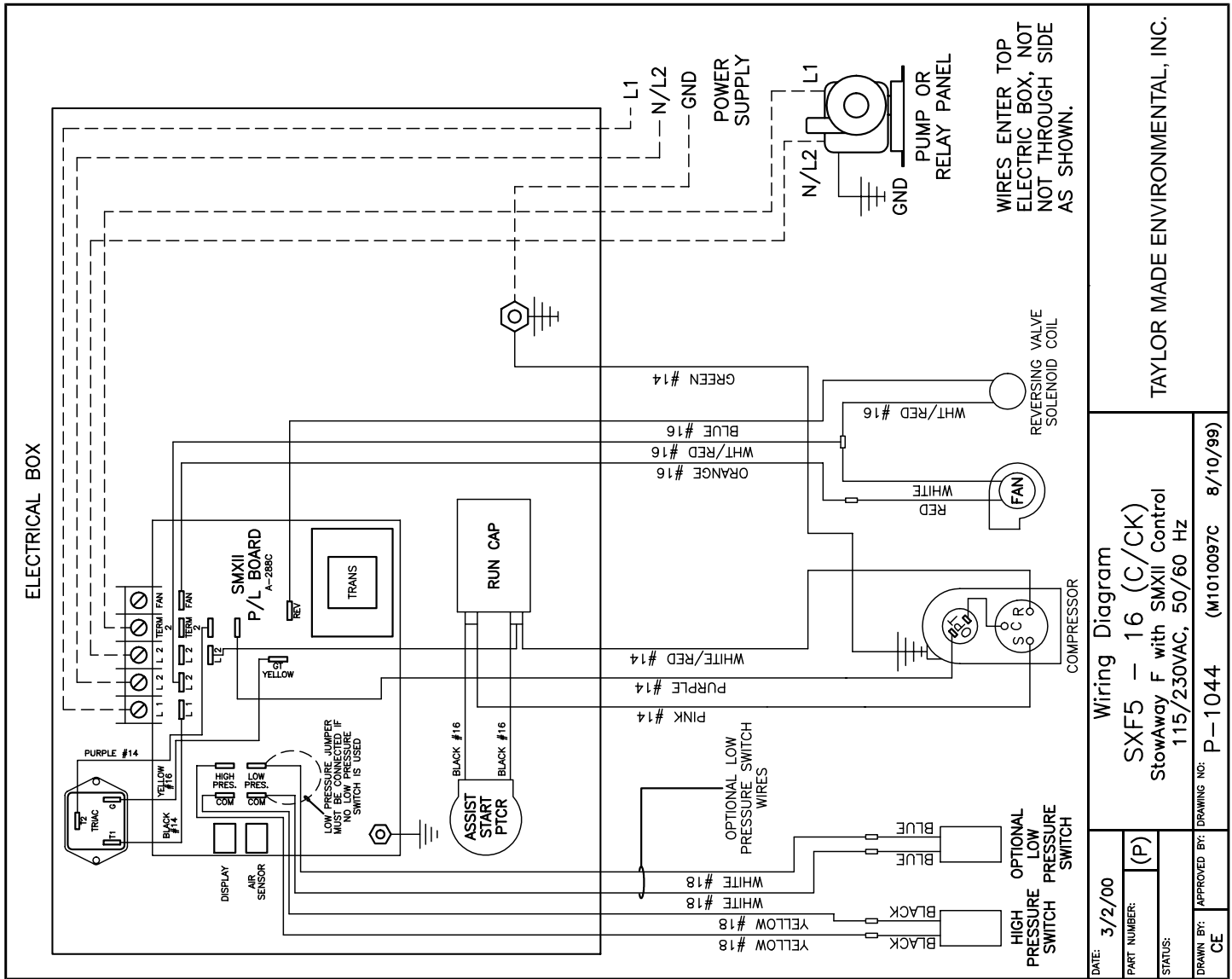

Figure 1. Explanation of SMX Net Inputs/Outputs

1) Aux. 1 Output

a) Can be set up to operate a line duty auxiliary heater. Setup code is explained in SMX Series Control Systems User's Guide (L-0634).

- OR -

b) Can be set up as a pump relay to operate a pump (for SMX Net only).

2) Aux. 1 Power In

a) Is the power supply feeding the auxiliary heater.

- OR -

b) Is the power supply feeding the pump if network is set up as a pump relay (SMX Net only). The Aux. 1 Power In can be jumped with Power In Primary as long as the supply circuit is not overloaded.

3) Power In Primary

a) Is the power supply feeding the SMX Power/Logic Board, Compressor, Blower(s), Reversing valve, Pump 1 (if used), and Aux. 2 (if used).

4) Blower

a) F1 - This output drives the variable speed evaporator blower(s) not exceeding 6 amps total blower load, or the high speed winding of a two speed blower motor. Set up code is explained in SMX Series Control Systems User's Guide (L-0634).

b) F2 - This output drives the low speed winding of a two speed blower motor.

- OR -

c) Aux. 2 - This output can drive an auxiliary load under 7 amps ON or OFF by the Convenience Panel (SMX Net only). (CAUTION: DO NOT overload the "Power In Primary" circuit ampacity if this output is used).

Figure 2. SMX Net Setup Codes

Function	Code	Factory Setting
EPROM Version	COOL & DOWN	60 = NET DX (with Heat Sink) 61 = Online DX (with Heat Sink) 62 = NET TW (with Heat Sink) 70 = NET DX (no Heat Sink) 72 = NET TW (no Heat Sink)
EPROM Revision	COOL & DOWN then UP	
Run Aux2 or Low Fan	OFF & SLOW	A0 = Off (Pressing UP toggles On/Off) A1 = On
AUX HEAT	SET & HEAT	AH = Aux Heat enabled "--" = Aux Heat disabled
Fan Differential	COOL & SLOW	4 = 4/8°F = 1/2°F per Fan LED
Local ID#	OFF & DOWN	"--" (Network must have Local ID)
Slave ID#	OFF & SET or DOWN & SLOW & FAST	"--" (with Heat sink) "--" (no Heat sink)
Pump ID#	OFF & TEMP	"--"

Enter all programming codes by pressing OFF, then SET, then the code simultaneously. Raise or lower the value by pressing UP or DOWN. Press OFF to exit the programming mode.

Testing Network

Test the network operation by entering the remote mode and scrolling through all Local ID #'s assigned.

Function	Code	Reason
Remote Mode	OFF & UP	Pressing UP or DOWN scrolls through all assigned Local ID#'s

If all Local ID#'s assigned cannot be scrolled through, check each display for outside temperature. If a display shows "--", this usually indicates a broken or misplugged network cable. A network break can be determined by following the cable, starting at the Blue plug from a unit that indicates "--" for outside temperature, to the Yellow plug on a unit that properly displays outside temperature. The break will be between these two connections.

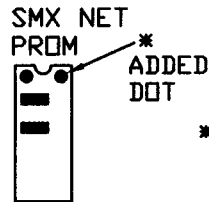
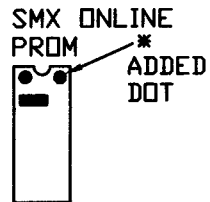
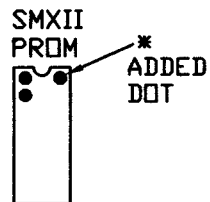
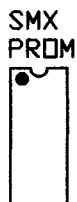

* DENOTES SMXII BOARD #4240302H A-281C & ONLINE & NET BOARDS.

** DENOTES SMXII "HV" BOARD #4240400 A-288C.

<u>EPRM #</u>	<u>MDC#</u>	<u>VER.</u>	<u>REV.</u>	<u>DESCRIPTION</u>	<u>COLOR CODE</u>
A-206	42204-06	06		SMX CRUISAIR DX & COACH DX HEATPUMP	YELLOW 1 DOT
	42206-20	20		SMX COACH COOLING ONLY (SMX-M20N & B)	GRAY 1 DOT
	42205-42	42		SMX TWS	BLUE 1 DOT
A-280C	42207-00	0b		SMXII CRUISAIR DX & COACH DX HEATPUMP	YELLOW 2 DOTS
A-280M	42208-20	24		SMXII COACH COOLING ONLY (A-286)	GRAY 2 DOTS
A-280T	42205-43	43		SMXII TWS	BLUE 2 DOTS
A-283C *	42210-30	30		SMXII CRUISAIR DX & COACH DX HEATPUMP	YELLOW 3 DOTS
A-283T *	42210-32	32		SMXII TWS	BLUE 3 DOTS
A-289C **	42210-37	37		SMXII "HV" CRUISAIR & COACH DX HEATPUMP "37" (LABEL)	
	42209-61	61		SMX ONLINE DX HEATPUMP	YELLOW 1 DOT & 1 DASH
A-283LMH	42209-65	65		SMX ONLINE COACH DX HEATPUMP W/AH	RED 1 DOT & 1 DASH
A-283LM	42209-67	67		SMX ONLINE COACH COOLING W/AH	GRAY 1 DOT & 1 DASH
				SMX ONLINE TWS	BLUE 1 DOT & 1 DASH
	42209-60	60	41	SMX NET DX HEAT PUMP	YEL 1 DOT & 2 DASHES
	42209-64	64		SMX NET COACH DX HEATPUMP W/AH	RED 1 DOT & 2 DASHES
	42209-66	66		SMX NET COACH COOLING W/AH	GRAY 1 DOT & 2 DASHES
	42209-62	62	0A	SMX NET TWS	BLUE 1 DOT & 2 DASHES
		69	0b	SMX PHONE MODEM	GREEN 1 DOT (LOCATED ON U10)
	42209-70	70		SMX NET DX HEAT PUMP	YEL 2 DOTS & 2 DASHES
	42209-72	72		SMX NET TWS	BLUE 2 DOTS & 2 DASHES
	42209-74	74		SMX NET COACH DX HEATPUMP W/AH/AF	RED 2 DOTS & 2 DASHES
	42209-75	75		SMX ONLINE COACH DX HEATPUMP W/AH/AF	RED 2 DOTS & 1 DASH
	42209-76	76		SMX NET COACH COOLING W/AH/AF	GRAY 2 DOTS & 2 DASHES

MODEL DISPLAY VERSION & REVISION LEVEL

SMX & SMXII — PRESS OFF THEN OFF-FAN-SET THEN COOL (UNTIL DISPLAY READS 68) THEN UP DISPLAYS VERSION. PRESS SLOW UNTIL DISPLAY READS F2 THEN UP TO DISPLAY REVISION.

** SMX ONLINE, NET & NEW SMXII — TO DISPLAY VERSION # PRESS OFF THEN SET THEN COOL-DOWN, THEN PRESS UP TO DISPLAY REVISION LEVEL.

TAYLOR MADE ENVIRONMENTAL, INC.		
SCALE: .5=1	APPROVED BY:	DRAWN BY: DR
DATE: 4/12/93	REVISED 1/14/00 DR	REVISED 1/14/00
SMX SOFTWARE LABELING		
		DRAWING NUMBER SKA-349

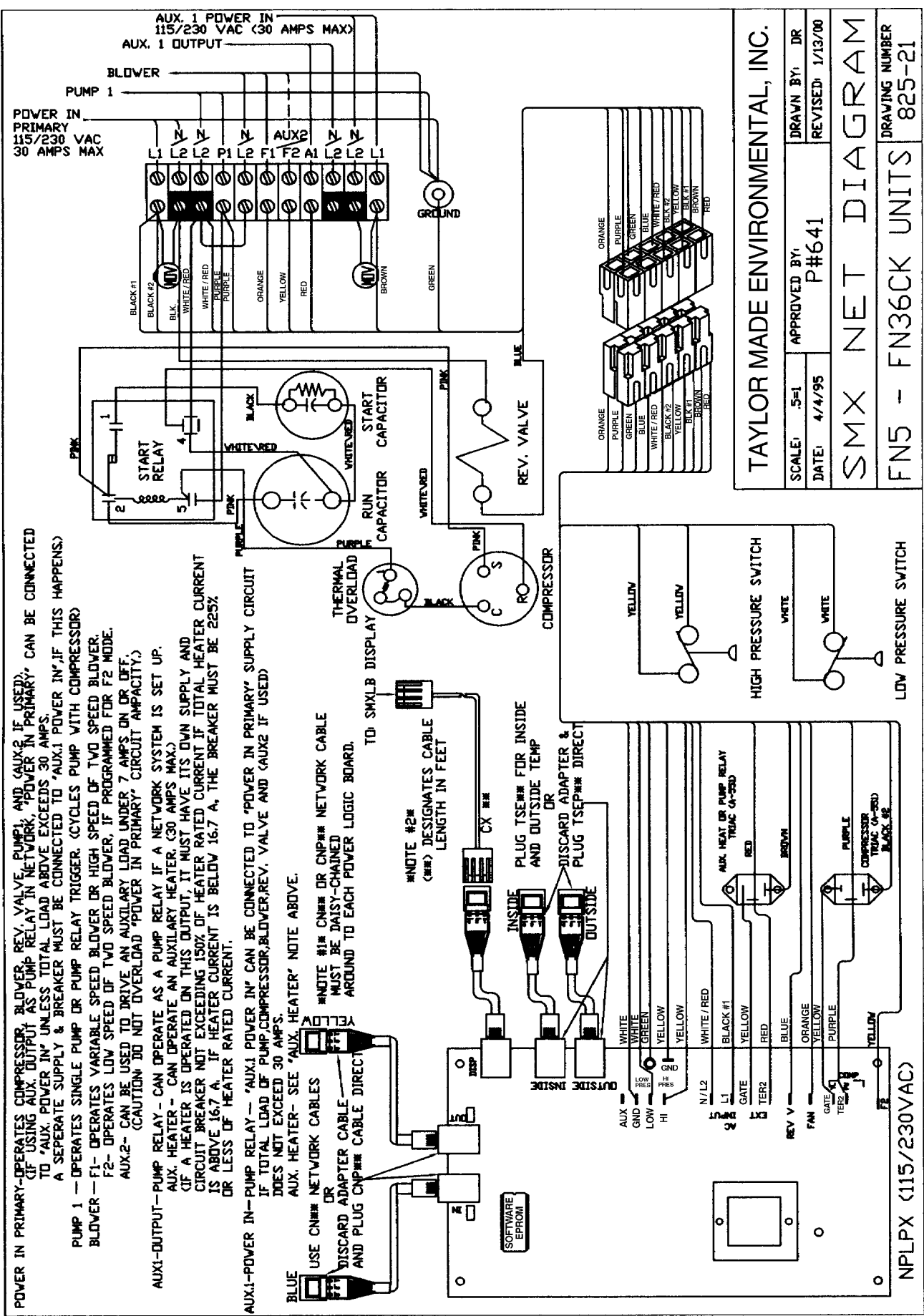

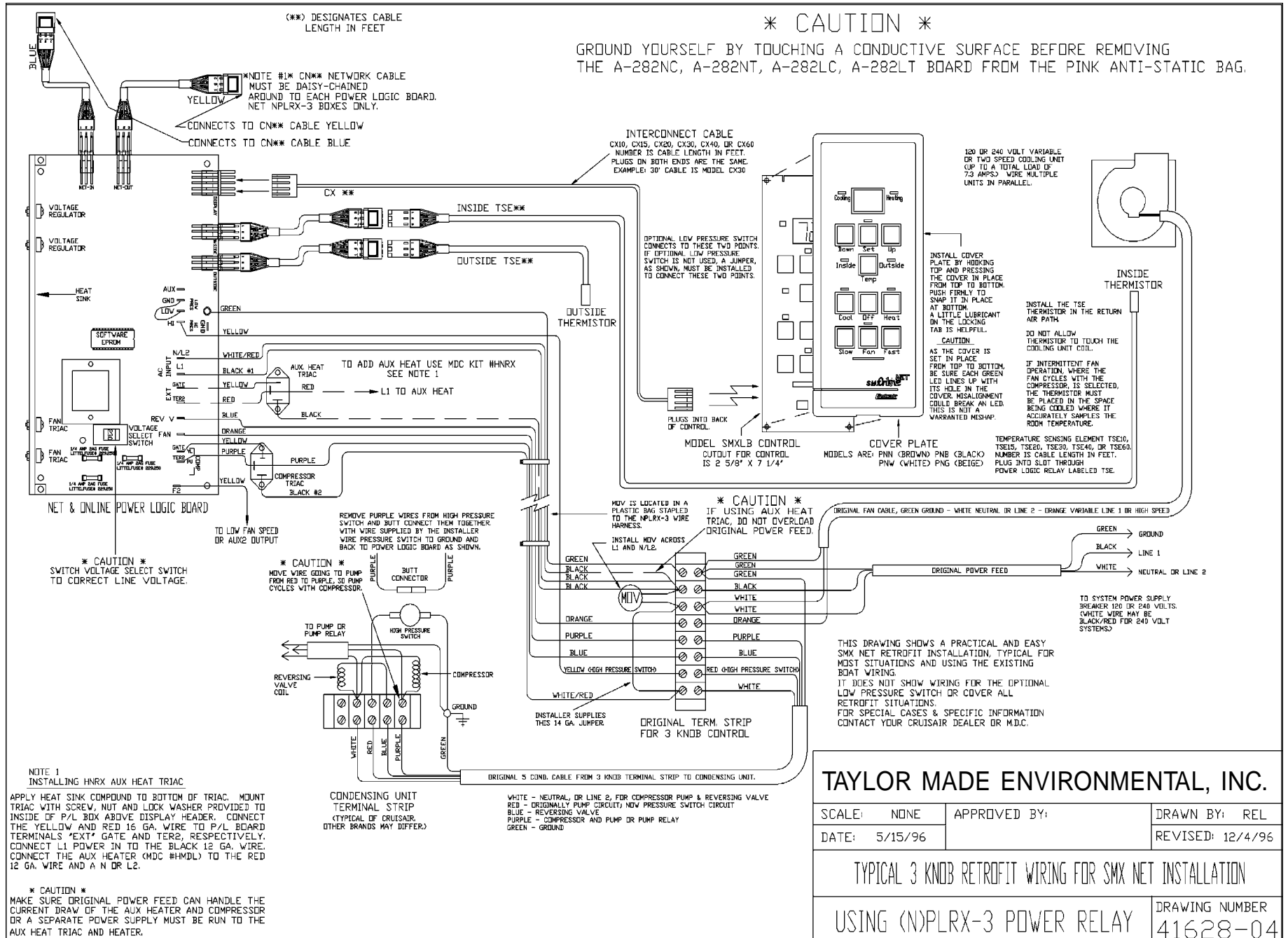

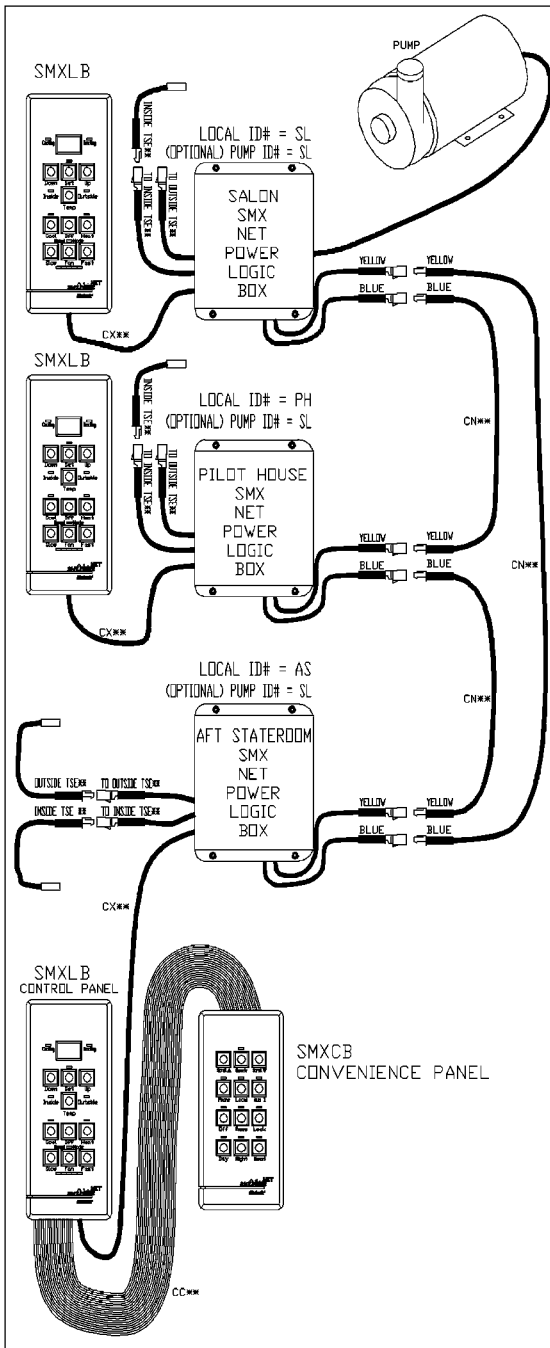

INSTALLING THE SMX NET SYSTEM

CONNECT ONE END OF THE CN CABLE TO THE MATCHING COLORED EXTENSION FROM THE POWER LOGIC BOX AND CONNECT THE OTHER END TO THE MATCHING COLORED EXTENSION OF THE NEXT POWER LOGIC BOX. CONTINUE THIS DAISY-CHAIN CONNECTION UNTIL ALL NETWORK POWER LOGIC BOXES ARE CONNECTED IN SERIES. ALSO, AN OPTIONAL NETWORK HUB CAN BE USED (REFER TO DRAWING #831-00 & #831-02) TO CONNECT ALL P/L BOXES TO A CENTRAL LOCATION INSTEAD OF DAISY-CHAINING THEM TOGETHER.

INSTALLING THE CONVENIENCE PANEL (NETWORK ONLY)

THE CONVENIENCE PANEL SMXCB MUST BE INSTALLED WITHIN 4' OF THE SMXLB CONTROL PANEL. THE CONVENIENCE PANEL IN CERTAIN CASES USES THE CONTROL PANEL DISPLAY. ON THE BACK OF THE CONVENIENCE PANEL AND CONTROL PANEL REMOVE THE BLACK RUBBER CAP COVERING THE EDGE CARD. PLUG ONE END OF THE CC* RIBBON CABLE TO THE CONTROL PANEL AND THE OTHER END TO THE CONVENIENCE PANEL, EDGE CARD CONNECTOR. CAUTION, MAKE SURE THE CC** RIBBON CONNECTOR HAS THE LABEL ON EACH CONNECTOR FACING THE FRONT OF THE CONVENIENCE AND CONTROL PANEL. THE CUTOUT SIZE FOR THE CONVENIENCE PANEL IS 2 5/8" X 6 1/4" ±1/16".

USING A PR8X TYPE PUMP RELAY

OR

USING A NETWORK POWER LOGIC BOX AS (OPTIONAL) PUMP RELAY

IF A PR8X TYPE PUMP RELAY IS USED, IGNORE THE BOTTOM PARAGRAPH. THE PUMP1 (P1) OUTPUT FROM EACH P/L TERMINAL STRIP CAN BE CONNECTED TO TRIGGERS IN THE PR8X. THE PUMP1 (P1) OUTPUT CYCLES WITH THE COMPRESSOR.

OR

IF A NETWORK P/L BOX IS GOING TO BE USED AS A PUMP RELAY, THE "AUX.1 POWER IN" NEEDS A SEPARATE POWER SUPPLY TO OPERATE THE PUMP OR THE "POWER IN PRIMARY" L1 & N/L2 CAN BE JUMPED TO THE "AUX. 1 POWER IN" L1 & N/L2. THE PUMP IS CONNECTED TO THE "AUX. 1 OUTPUT" A1 & N/L2. THE P/L BOX THAT IS SET UP AS A PUMP RELAY MUST BE MARKED WITH THE LABEL PROVIDED IN THE LITERATURE PACKAGE. NEXT, THE PUMP ID# OF ALL P/L BOXES IN THE NETWORK MUST BE SET TO THE CONTROLLER ID# THAT IS OPERATING THE PUMP. FOR EXAMPLE IF THE PUMP IS CONNECTED TO THE P/L BOX WHICH HAS A CONTROLLER ID#SL THEN SET ALL P/L BOXES THAT USE THE PUMP TO A PUMP ID#SL INCLUDING THE UNIT OPERATING THE PUMP. ONE WORD OF CAUTION. IF THE P/L BOX WHICH IS THE PUMP RELAY FAILS, THE PUMP WILL NOT OPERATE. A NPTSA TEST SWITCH ASSEMBLY CAN BE USED TO BY-PASS THE FAILED P/L BOX AND OPERATE THE PUMP CONTINUOUSLY. ALL PUMP ID#S MUST BE SET BACK TO "--", IF THIS TEST SWITCH IS USED.

** DESIGNATES CABLE LENGTH IN FEET.

ONLY ONE OUTSIDE TSE** IS REQUIRED FOR A NETWORK SYSTEM.
ALL P/L BOXES WILL READ THE SAME TEMP.

TAYLOR MADE ENVIRONMENTAL, INC.

SCALE: NONE	APPROVED BY:	DRAWN BY: REL
DATE: 11/21/96		REVISED:

INSTALLATION DIAGRAM SMX NETWORK

SYSTEM WITH CONVENIENCE PANEL	DRAWING NUMBER 083200
-------------------------------	--------------------------

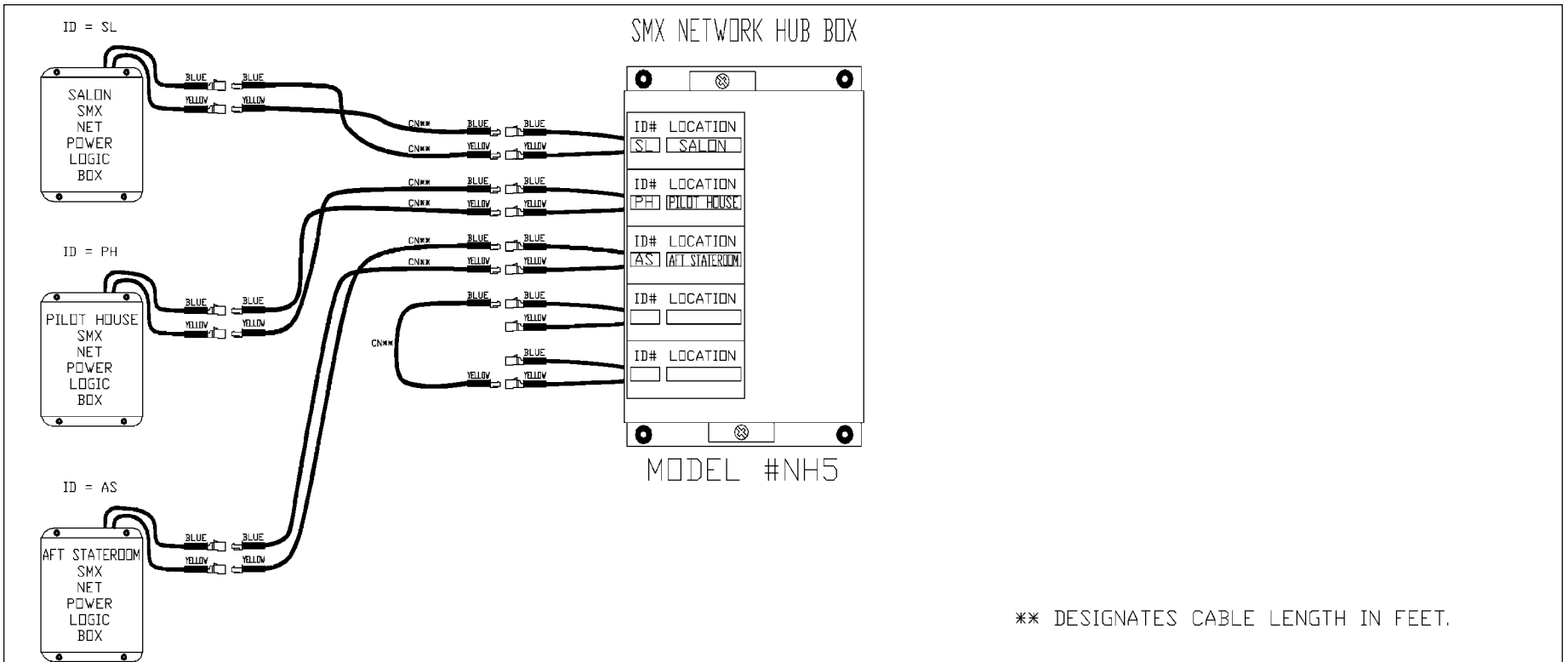

** DESIGNATES CABLE LENGTH IN FEET.

THE SMX NETWORK CAN BE CONNECTED BY DAISY-CHAINING THE CN** CABLE FROM ONE POWER LOGIC BOX TO ANOTHER, OR BY USING THE #NH5 SMX NETWORK HUB BOX AS SHOWN ABOVE.

CONNECT THE CN** CABLE FROM THE POWER LOGIC BOX TO ONE PAIR OF BLUE AND YELLOW CONNECTORS AT THE NET HUB BOX. CONNECT EACH POWER LOGIC BOX TO THE NET HUB BOX IN ORDER STARTING FROM THE UPPER LEFT CORNER AND WORKING DOWN. IF ONLY THREE POWER LOGIC BOXES ARE CONNECTED AS SHOWN ABOVE, THE NEXT YELLOW CONNECTOR DOWN FORM THE LAST CONNECTION AND THE LAST BLUE CONNECTOR MUST BE JUMPED TOGETHER WITH A CN** CABLE.

TAYLOR MADE ENVIRONMENTAL, INC.		
SCALE: NONE	APPROVED BY:	DRAWN BY: REL
DATE: 4/24/96		REVISED:
INSTALLATION DIAGRAM		
SMX NETWORK HUB BOX		DRAWING NUMBER NTHUBE04 831-02

WARNING

Taylor Made Environmental, Inc. (TME) manufacturers of Cruisair, Grunert, Marine Air and Sentry Products, makes the following safety warnings concerning the application, installation, use and care of its products. Although these warnings are extensive, there may be specific hazards which may arise out of circumstances which we have not outlined herein. Use this as a guide for developing an awareness of potential hazards of all kinds. Such an awareness will be a key factor in assuring your SAFETY and comfort.

ELECTRICITY - Many TME products operate on 115, 230 or 440 volt AC power. Such voltages can be LETHAL; therefore, the chassis, cabinets, bases, etc., on all components must be grounded together and connected to the vessel's grounding system. Sparks can occur as switches, thermostats and relays open and close in the normal operation of the equipment. Since this is the case, ventilating blowers for the removal of hazardous fumes or vapors should be operated at least 5 minutes before and during operation of any TME product or group of TME products. All electrical connections must be covered and protected so accidental contact cannot be made by persons using the equipment, as such contact could be LETHAL.

ELECTROLYSIS - Electrical leakage of any component can cause electrolytic deterioration (electrolysis) of thru-hull components which could result in leakage serious enough to sink a vessel which could result in loss of life. All TMES components must be kept clean and dry and checked periodically for electrical leakage. If any electrical leakage is detected, the component should be replaced or the fault causing the leakage corrected before the component is put back into service.

GAS - CRUISAIR, MARINE AIR and GRUNERT components utilize R134a refrigerant, tetrafluoro-ethane or R404A, R125/R143a/R134 (44%/52%/47%) which are non-toxic, non-flammable gases; however, these gases contain no oxygen and will not support life. Refrigerant gas tends to settle in the lowest areas of the compartment. If you experience a leak, evacuate all personnel, and ventilate area. Do not allow open flames in the area of leaks because refrigerant gas, when burned, decomposes into other potentially LETHAL gases. Refrigerant components operate at high pressure and no servicing should be attempted without gloves, long-sleeved clothing and eye protection. Liquid refrigerant gas can cause severe frost burns to the skin and eyes.

VENTILATION - To cool or heat air, CRUISAIR, MARINE AIR and GRUNERT components are designed to move air through a heat exchanger by a blower or propeller fan. This design necessarily produces a suction on one side of the air handling component and a pressure on the other side. Air handling components must be installed so that the suction-pressure action does not: (1) pressurize an area to the extent that structural failure occurs which could cause harm to occupants or bystanders, or (2) cause a suction or low pressure in an area where hydrogen gas from batteries, raw fuel vapor from fuel tanks, carbon monoxide from operating propulsion engines, power generators or heaters, methane gas from sewage holding tanks, or any other dangerous gas or vapor could exist. If an air handling unit is installed in such a manner that allows potentially lethal gases or vapors to be discharged by the air handling unit into the living space, this could result in loss of life.

Maximum protection against the introduction of dangerous gases or vapors into living spaces can be obtained by providing living spaces which are sealed from all other spaces by use of airtight bulkheads and decks, etc., and through the introduction of clean air into the living space. Bear in mind that the advent of air conditioning, whether it be for cooling or for heating, naturally leads to the practice of closing a living space tightly. Never close all windows and doors unless auxiliary ventilating systems, which introduce clean outside air into the living space, are used. Always leave enough window and door openings to provide adequate ventilation in the event potentially lethal gases or fumes should escape from any source.

CONDENSATE - All cooling units produce water condensate when operating on the cooling cycle. This water must be drained from the cooling unit overboard. If condensate is allowed to drip on a wooden structure, rotting or decay and structural failure may occur which could result in loss of life. If condensate is allowed to drip on electrical components, deterioration of the electrical components could result in hazardous conditions. When an air conditioning system is in operation, condensate drains may be subjected to negative pressure. Always locate condensate drains as far as possible from points where engine waste and other dangerous gases are exhausted so no such dangerous gases can be drawn into the condensate drains.

Warning

Never sleep in a closed area on a boat when any equipment, which functions as a result of the combustion of a volatile fuel, is in operation (such as engines, generators, power plants, or oil-fired heaters, etc.) At any time, the exhaust system of such devices could fail, resulting in a build-up of LETHAL gases within the closed area.

Notes:



Taylor Made
ENVIRONMENTAL™

P.O. Box 15299 • Richmond, VA 23227-0699 USA
Telephone: 804-746-1313 • Facsimile: 804-746-7248 • E-mail: sales@tmenviro-va.com • www.tmenviro.com

©Taylor★Made is a registered trademark of Nelson A. Taylor Co., Inc.; the Taylor Made Group logo is a trademark of Taylor Made Group, Inc.; the Cruisair logo is a registered trademark & the Taylor Made Environmental logo is a trademark of Taylor Made Environmental, Inc.

A Member of
THE
TAYLOR MADE
GROUP.

L-0503