



Self-Contained and Split System Reverse Cycle Air Conditioners

Self-Contained Models SA 05-07-10-12-16-18-24 and
Split System Models CA (Compressor Section) & DEAH (Evaporator Section)

Owner's Manual



Self-Contained Unit



Split System Unit



Chapter 1: Safety Considerations	2
Chapter 2: Routine Maintenance	3
Chapter 3: General Description	7
Chapter 4: Thermostats and Controllers	8
4.1 o-LED Thermostat/Controller	8
4.2 MachAir I Thermostat Controller	17
Chapter 5: Winterizing the System	34
Chapter 6: Troubleshooting	35
Chapter 8: Warranty	39

Manufactured by:

Marvair® Division of AIRXCEL®, Inc

PO Box 400 • Cordele, GA 31010
156 Seedling Dr. • Cordele, GA 31015
(229) 273-3636 • Fax (229) 273-5154
Email: marvair@airxcel.com
www.marvair.com

Marvair® Marine UK

Unit B8 • Arena Business Centre • Holyrood Close
Poole, Dorset BH17 7FL.
+44 1202 606405
www.marvair.co.uk

Marvair® Reverse Cycle Air Conditioners

Chapter 1 – Safety Considerations

Congratulations on your purchase of a Marvair® marine air conditioner. Your air conditioner has been designed to provide years of safe, dependable operation. These instructions contain a general description on the operation of the unit, how to set up or program the thermostat/ controller, a list of routine maintenance items, basic trouble shooting information, and the warranty.

The first thing we recommend for you to do is to write down the model number and the serial number of the unit. Both numbers can be found on the data label on the unit. Refer to them whenever you call upon your Marvair® dealer regarding this unit.

Model No. _____

Serial Number _____

Safety Considerations

This is the safety alert symbol . When you see this symbol on the Marvair® unit and in the instruction manuals be alert to the potential for personal injury. Understand the signal word DANGER, WARNING and CAUTION. These words are used to identify levels of the seriousness of the hazard.

 **DANGER** Failure to comply will result in death or severe personal injury and/or property damage.

 **WARNING** Failure to comply could result in death or severe personal injury and/or property damage.

 **CAUTION** Failure to comply could result in minor personal injury and/or property damage.

IMPORTANT is used to point out helpful suggestions that will result in improved installation, reliability or operation.

DANGER

Self-contained units or evaporators of split systems should never be installed in engine rooms or other areas where fuel, battery or bilge vapors may be introduced to the living quarters on board.

These components do not meet federal requirements for ignition protection. Do not install in spaces containing gasoline engines, tanks, LPG/CPG cylinders, valves, fuel line fittings, or regulators. Failure to comply may result in injury or death. (Condensing units do comply with USCG/ABYC Ignition Protection standards and may be installed in engine compartments.)

Do not terminate condensate drain line within four feet of any outlet of engine or generator exhaust systems, nor in a compartment housing an engine or generator.

Installation and servicing of this system can be hazardous due to system pressure and electrical components. When working on this equipment, always observe precautions described in the literature, tags and labels attached to the unit(s). Follow all safety codes.

Marvair recommends that you use only factory certified, EPA licensed refrigerant technicians and qualified marine electricians. ABYC certification in both HVAC and Marine electrical trades is desirable. In receiving these certifications, a technician and his employer has made a statement of commitment to professional, technically proficient and reliable service.

CAUTION

Under both heating and cooling modes of operation, certain components will run at fairly high temperatures. Exercise care in working around operating equipment. Do not touch operating machinery without the aid of qualified personnel, as referred to above.

Marvair® Reverse Cycle Air Conditioners

Chapter 2 - Routine Maintenance

Return Air Filters

Return air filters should be cleaned regularly. The filter shipped with your Marvair® unit is located in front of the air coil.

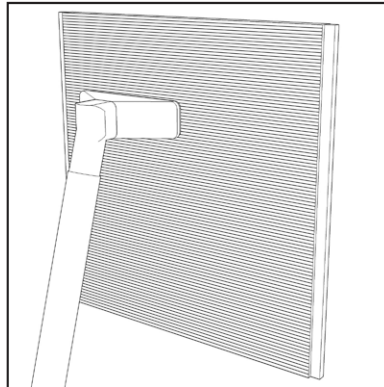

Figure 1. Filter can be cleaned with a vacuum cleaner.

Condensate Pan and Lines

The condensate line can develop an algae type growth. Periodic inspection and treatment with a mild solution of bleach and water poured into the condensate pan will keep the condensate pan and lines clear. In split systems, the condensate pan is in the DEAH (air handler).

Sea Water Strainer

The seawater strainer is available in several configurations – bronze or plastic. Yours has been sized in accordance to system specifications for volume of water required. It is used to prevent debris such as eelgrass, sea weed, leaves, etc., from passing through the system water lines and condensing coil. These items could lodge themselves in the water supply causing possible shutdown faults, and left unchecked, equipment damage. Should the strainer become clogged or partially obstructed, adverse performance will be experienced. The first indication will be a high pressure switch activation if the unit is in the cooling mode or low pressure if the unit is in the heating mode. The unit will shut down. Turn unit off; check strainer and pump, restart. (See Sea Water Pump and Troubleshooting.)

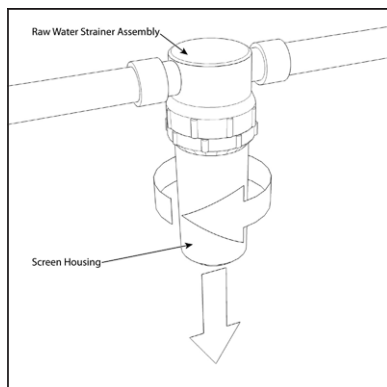

Figure 2a. Unscrew and remove Screen Housing

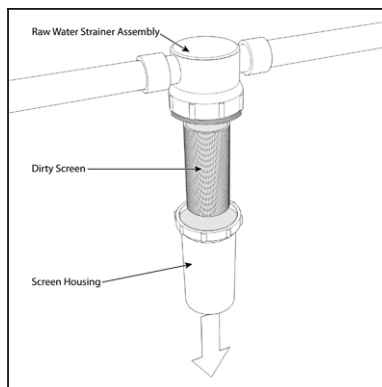

Figure 2b. Remove dirty Screen

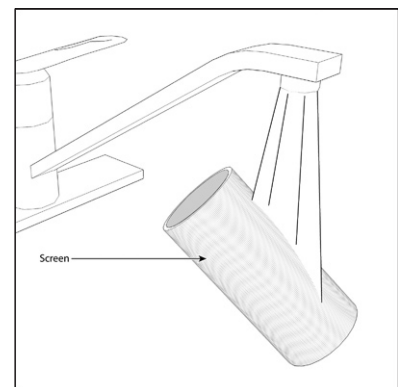

Figure 2c. Rinse Screen with clean water. Reinstallation is the reverse of removal

Marvair® Reverse Cycle Air Conditioners

To eliminate these potential problems, it is recommended that you check to make sure you have water flow each time you turn the system on and clean your strainer weekly. More often as conditions dictate. Localized situations: In some regions, it is common to experience a tremendous presence of jellyfish or sea nettles concentrated in back bay marinas for short periods of time. These can clog strainers and water pumps every hour to hour and a half in some cases. In such severe conditions, seek the advice of your local factory service representative. They will be most familiar with solutions to localized situations. Marvair works closely with our servicing dealers when custom solutions are required. During the warranty period, factory approval must be obtained for any modification to be done to alleviate the problem.

Sea Water Pump Operation and Maintenance

Your seawater pump has been sized in accordance with specifications for system water flow and volume. While it will shut down to protect from damage, it is not advisable to run the seawater pump dry. Possible damage may still be incurred. *Damage incurred due to a pump running dry is not covered under warranty.* The pump is not self-priming. It must be initially primed upon commissioning. Properly installed, once primed, barring haul outs or interrupted water flow due to an external cause, it should not need to be primed again.

Occasionally, sea grass, jellyfish and other items may pass through your strainer and get lodged in the pump impeller. Should cleaning your strainer fail to eliminate a water flow problem, you should next contact your Marvair® Marine air conditioner service technician.

Units that have the thermostat may have the optional pump sentry monitor. Please see page 14 for a description of the pump sentry.

Minimum Water Flow* for Marvair® Reverse Cycle Self-Contained Systems	
Model (BTUH)	Minimum Water Flow at the Unit
5,000	1.4 GPM / 5.3 LPM
7,000	2.0 GPM / 7.6 LPM
10,000	2.9 GPM / 11.0 LPM
12,000	3.5 GPM / 13.3 LPM
16,000	4.7 GPM / 17.8 LPM
18,000	5.25 GPM / 19.9 LPM
24,000	7.0 GPM / 26.5 LPM

*Based upon 85°F (29.5°C) inlet water measured at the inlet of the SeaMach unit.

Table 1. Minimum Water Flow Chart

Grilles and Proper Air Flow

Adequate air flow is essential for the proper operation of the air conditioner. All grilles, both supply and return air, must never be restricted by objects such as bed linens, duffel bags, tackle bags, etc. Your unit has been designed to deliver conditioned air over a wide range of conditions. However, a dirty filter, or restricted ductwork can prevent proper air flow. If this situation exists and the unit is in cooling mode, ice may form on the coil and the unit will go into the defrost mode.

The unit may go into the Defrost mode or for the HPS alarm to be displayed occasionally. However, repeated Defrost cycles or High Pressure notices indicate a problem and you should contact your Marvair®

Marvair® Reverse Cycle Air Conditioners

Marine dealer or the factory. If you have the MachAir I controller, no indication is made on the display when the unit enters the Defrost Mode.

If you have the o-LED thermostat controller, when a high refrigerant pressure is detected, High Refrigerant Pressure is shown on the screen of the thermostat.

Return Air Grille(s) and Filter(s)

Return air grilles are available in both aluminum and wood in standard configurations. They do not have adjustable louvers and are available with and without filters. Return air filters should be cleaned regularly. The filter shipped with your unit is located in front of the air coil and can be cleaned with a vacuum cleaner or rinsed with fresh water.

If your unit's return air grille has a filter, be sure that your boat builder or installation technician has removed the standard filter that comes with every unit in front of the evaporator (air) coil. Two filters can unduly restrict air flow and in some cases, cause problems with performance. Use EITHER a return air filter grille or the supplied filter, **never both**.

Depending upon the floor plan, your boat's space constraints may dictate that a unit be installed in an area that makes it difficult to access and clean the filter. If this is the case, and you do not have a return air filter grille, you should consider removing the disposable unit filter and upgrading to a return air filter grille.

NOTE: Blocking the return air grille or neglecting filter cleaning will result in a restriction of air flow. In the heating mode, this will cause a HIGH PRESSURE FAULT shutdown. In the cooling mode, after a period of time, you will experience icing of the evaporator coil and a resultant LOW PRESSURE FAULT shutdown or activation of the defrost sensor.

Supply Air Grille(s)

Most installations will have more than one supply air grille. Standard main supply air grilles are generally made of aluminum or wood frames with two or four-way adjustable louvers. These may be adjusted to direct air flow from the grille to ensure a uniform cabin temperature. Main supply air grilles should never be closed at any time while running in either the heating or cooling modes. Secondary supply air grilles more frequently will be a 4" round plastic design, but they can also be of the aluminum or wood frame standard configuration and are usually located out of the main salon, galley, dinette area. These may, depending upon the style you or your boat manufacturer has chosen, be closable. During the day, these may be closed should you like more air directed to the main living area. Consult with your local Marvair® Marine service representative if you are unsure which are the main supply grilles on your boat. Closing off the main supply air grille or secondary air grilles, in some applications, may restrict air flow in the cooling mode, cause ice to form on the evaporator coil and a low pressure fault shut down. If the unit is in the heating mode, inadequate air flow can cause a high pressure fault shut down.

Should either of these conditions occur, open all closed supply air grilles and restart system. This should eliminate the problem. If the problem recurs again, consult your local Marvair Marine service representative.

Marvair® Reverse Cycle Air Conditioners

Self Contained Unit or Air Handler	Nominal Air Flow CFM/m ³ per Hour	Minimum Opening for Return Air Grille (in ² /cm ²)	Minimum Opening for Supply Air Grille(s) (in ² /cm ²)	Minimum Hose Size (in/cm)	Marvair P/N for Blower to Hose Adapters	Outside Diameter of Hose Adapter (in/cm)
5,000	150/255	64/415	32/210	4/10.2	Not required. Blower has 4" (10.2cm) round diameter opening.	Not required. Blower has 4" (10.2cm) round diameter opening.
7,000	250/425	100/645	40/260	5/12.7	90134 ¹ (5" round hose adapter)	4-3/4" (12cm)
10,000	300/510	100/645	60/390	5 or 6*/12.7 or 15.2*	90134 (5" round hose adapter) or 90135 ¹ (6" round hose adapter)	4-3/4" (12 cm) or 5-3/4" (14.6 cm)
12,000	360/612	140/900	70/450	6/15.2	90135 ¹ (6" round hose adapter)	5-3/4" (14.6 cm)
16,000	385/654	168/1,110	84/540	6 or 7*/15.2 or 17.8*	90135 (6" round hose adapter) or 90136 ¹ (7" round hose adapter)	5-3/4" (14.6 cm) or 6-3/4" (17.15cm)
18,000	420/714	168/1,110	84/540	7/17.8*	90136 ¹ (7" round hose adapter)	6-3/4" (17.15cm)
24,000	700/1,190	240/1,550	192/1,240	8* or 10/20.3* or 25.4	90568 ² (8" oval hose adapter)	10" x 4" (25.4 x 10.2 cm)

* Use larger size if duct run is greater than 10 ft. (3 meters).
¹Shipped standard with unit.
²Two adapters are shipped with each two ton unit.

Table 2. Air Flow and Grille Chart

Marvair® Reverse Cycle Air Conditioners

Chapter 3 - General Description

The Marvair® line of reverse cycle air conditioners built by Marvair® are self-contained and split system, water-cooled units designed for use with either fresh or seawater. The units are built in various sizes with capacities from 5,000 to 24,000 BTUH. Both 115 volt and 230 volt models are available. The units are designed to be controlled with a thermostat/ controller. Please refer to the model number designator to determine the exact specifications for your unit.

Model Identification - Self-Contained Units

S	A	•	••	••	•	•	••
S = Marine	Refrigerant A = R-410A C = R-407c	Controller B = Electronic Control Board	Nominal Capacity 05 = 5,000 BTUH 07 = 7,000 BTUH 10 = 10,000 BTUH 12 = 12,000 BTUH 16 = 16,000 BTUH 18 = 18,000 BTUH 24 = 24,000 BTUH	System Type AC = Air Conditioner RC = Reverse Cycle	Voltage A = 208/230V, 1ø, 60 Hz B = 115V, 1ø, 60 Hz F = 220V, 1ø, 50 Hz	Orientation* L = Left Hand R = Right Hand	Electronic Thermostat/ Controller M2 = o-LED Board

Note: 18,000 BTUH models are only available with 60 Hz units.

Model Identification - Split System Condensing Section

C	A	•	••	••	•	••
Marine	Refrigerant A = R-410A C = R-407c	Controller B = Control Board	Nominal Capacity 07 = 7,000 BTUH 10 = 10,000 BTUH 12 = 12,000 BTUH 16 = 16,000 BTUH 18 = 18,000 BTUH 24 = 24,000 BTUH	System Type AC = Air Conditioner RC = Reverse Cycle	Voltage A = 208/230V, 1ø, 60 Hz B = 115V, 1ø, 60 Hz F = 220V, 1ø, 50 Hz	Electronic Thermostat/ Controller M2 = o-LED Board

Note: 18,000 BTUH models are only available with 60 Hz units.

Model Identification - Split System Air Handler Section

DEAH	••	••	•	•
Direct Expansion Air Handler	Nominal Capacity 07 = 7,000 BTUH 10 = 10,000 BTUH 12 = 12,000 BTUH 16 = 16,000 BTUH 18 = 18,000 BTUH 24 = 24,000 BTUH	System Type AC = Air Conditioner RC = Reverse Cycle	Voltage A = 208/230V, 1ø, 60 Hz B = 115V, 1ø, 60 Hz F = 220V, 1ø, 50 Hz	Orientation* L = Left Hand R = Right Hand

* When looking at the compressor from the end of the unit, if the coil is on your right side, the unit is a right handed unit. If the coil is on your left, it is a left handed unit.

Operating Ranges

The Marvair® reverse cycle air conditioner is designed to operate over a wide variety of conditions. Among the most important factors that affect the performance of the unit are inlet water temperature, (return) inlet air temperature and the humidity of the inlet (return) air. Please consult your Marvair® Marine dealer or the factory if you have a question about the operation of your unit.

Marvair® Reverse Cycle Air Conditioners

General Operation

The Marvair® reverse cycle air conditioner has both a heating and cooling mode of operation.

It uses refrigerant in a conventional vapor compression cycle to transfer heat from the air in the boat to the water. In the cooling mode, a blower blows the cabin air through the indoor or evaporator coil where it is cooled and dehumidified. Liquid refrigerant passing through the evaporator is boiled into a gas by heat removed from the air. The warmed refrigerant gas enters the compressor where its temperature and pressure are increased. The hot refrigerant gas travels to the water coil or condenser where it is cooled by the water and condenses to a liquid. Liquid refrigerant is metered back into the evaporator coil to repeat the process.

In the heating mode, the process is reversed. A special reversing valve reverses the flow of the refrigerant throughout the system exchanging the roles of the condenser and evaporator. The refrigerant flows through the water or evaporator coil, picks up heat from the water, and becomes a vapor. The vapor then enters the compressor where it is compressed to a higher temperature. It is then pumped to the indoor coil where the air moving across the coil picks up the heat and the warm air is blown into the room. The compressed refrigerant vapor condenses to a liquid as it gives up heat. Finally, liquid refrigerant flows into the capillary tubes into the indoor coil where the cycle is repeated.

The reverse cycle air conditioner is controlled by a thermostat mounted on the wall.

In the self-contained units, all the components are in a single package. In a split system, the compressor and the water coil are one unit, called the compressor section, and the air coil and the blower are in another, called the evaporator or blower section. Field installed copper refrigerant lines and control wiring connect the two units. Cooling and heating performance of the two units is virtually identical.

Chapter 4 - Thermostats and Controllers

Your Marvair® Marine unit is controlled by the o-LED or MachAir I thermostat controller. All evaporator sections (models DEAH) for the split systems can be used with either the the MachAir I thermostat controller or the o-LED thermostat/ controller. Please refer to the appropriate section of this manual for operating your thermostat. Determine which unit you have installed and proceed with the appropriate instructions for setting up the thermostat.

Self contained and split models using the o-LED and the MachAir I thermostats have an air sensor factory installed in front of the face of the evaporator coil. Make sure the sensor is oriented so that air will be pulled across the sensor. See photo at right.

The end of the sensor cable should be plugged into the Alt Air port on the control board. See drawing on page 16.

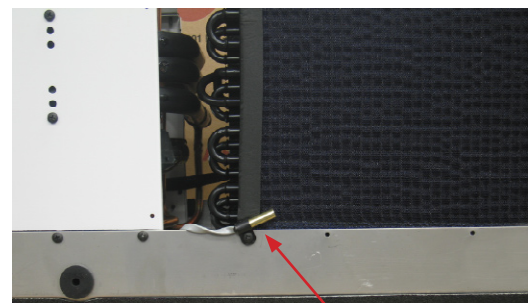

Air Sensor

The solid state control board in the unit will operate either the o-LED or the MachAir I display. The board is factory configured to operate the o-LED display. If you have the MachAir I display two pins must be moved on the board. Refer to the set-up for the MachAir I controller, section 4.2, for instructions on

Marvair® Reverse Cycle Air Conditioners

moving the pins. Before setting up either thermostat:

1. Turn the seacock valve to the open position
2. If the water pump has a dedicated breaker, turn it on. Verify that water is being discharged overboard.
3. Turn on the circuit breaker to the Marvair® unit.

Instructions for the o-LED can be found in section 4.1, starting below. Instructions for the MachAir I can be found in Section 4.2, starting on page 17.

4.1 Instructions for the o-LED Thermostat/Controller

General Description

The Marvair® digital controller operates onboard air conditioning equipment to provide room temperature control and humidity reduction. It allows for easy adjustment of fan speed, operating mode and temperature in a wide variety of applications. The Marvair® digital controller is designed to operate with self contained and central type marine air-conditioning systems.

Features include:

- **High visibility Organic Light Emitting Diode display (OLED) offers superior visual characteristics compared to LCD displays.**
- **Variable brightness adjustment and automatic screen saver.**
- **Four position menu navigation switch featuring a joystick style interface with push on / push off control.**
- **Built in room temperature sensor.**
- **The display is compatible with Vimar and Gewiss frames.**
- **Visual symbols enable the viewer to see the operating status at a glance.**
- **Easily programmed for customized operation.**
- **Both automatic and manual six level fan speed adjustment.**
- **Built in options for fault protection for Voltage, Current and refrigerant pressure.**
- **De-icing cycle to prevent evaporator icing.**
- **Automatic moisture mode provides relative humidity control.**
- **Universal 115/230 VAC 50/60 Hz power supply.**

Optional features include:

- **Outside air temperature sensor.**
- **Alternate air sensor.**
- **Pump sentry water sensor.**

Marvair® Reverse Cycle Air Conditioners

When You Start:

1. Applying power: Turning the Thermostat/controller on

When power is first applied, the display will show the software revision, and then return to the last state the unit was in when power was removed.

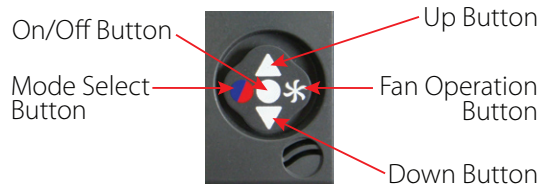

Joystick operation:

The four position joystick may be tapped up, down, right, left or in the center to make changes to the operation of the control. Gently tap this switch to operate it. **Excessive force will damage the switch.**

2. Operating states:

The display operates in two operational states. In the *OFF* state, the temperature is displayed and only fan operation is available. In the *ON* state, the display shows the temperature set point, room temperature, fan, and compressor status. Switch between these states by pressing and releasing the On/Off button.

4. Symbol animation:

Some symbols on the display use animation to indicate operation of part of the system.

Operating Screens

Screen Saver

In screen saver, the display will appear dim and the information will scroll across the screen. Status symbols appear as needed and operation continues in the mode selected. The brightness of the screen in the screen saver mode can be changed in the program screen. See page 13, parameter no. 4. To exit this mode, just tap any button.

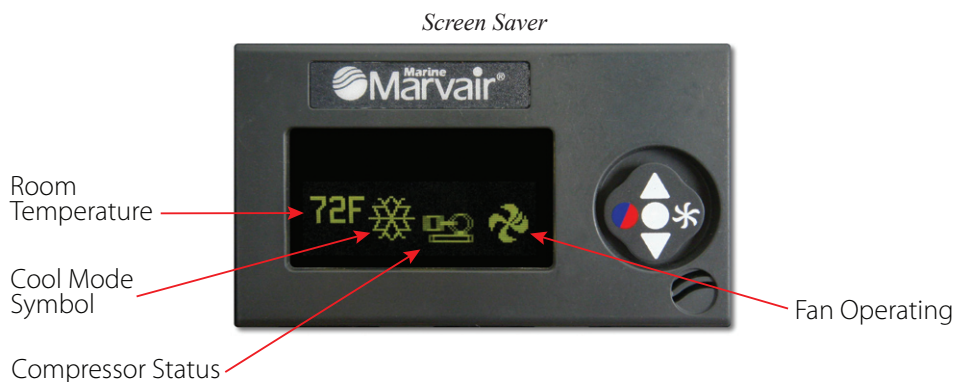

Marvair® Reverse Cycle Air Conditioners

Cool Mode

To select cooling only, tap the mode select button to scroll through the symbols in the top left of the display until the cool symbol appears. Set the desired room temperature by tapping the up or down button. The system will provide cooling as necessary. The compressor symbol will appear when system is cooling.

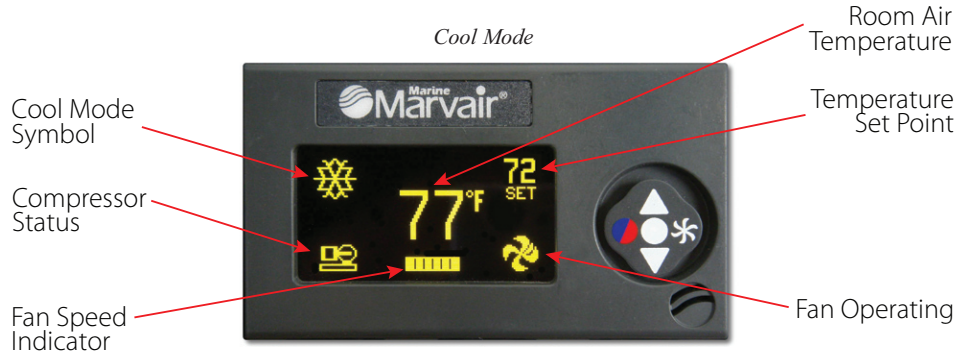

Heat Mode

To select heating only, tap the mode select button to scroll through the symbols in the top left of the display until the heat symbol appears. Set the desired room temperature by tapping the up or down button. The system will provide heating as necessary. The compressor symbol will appear when the system is heating.

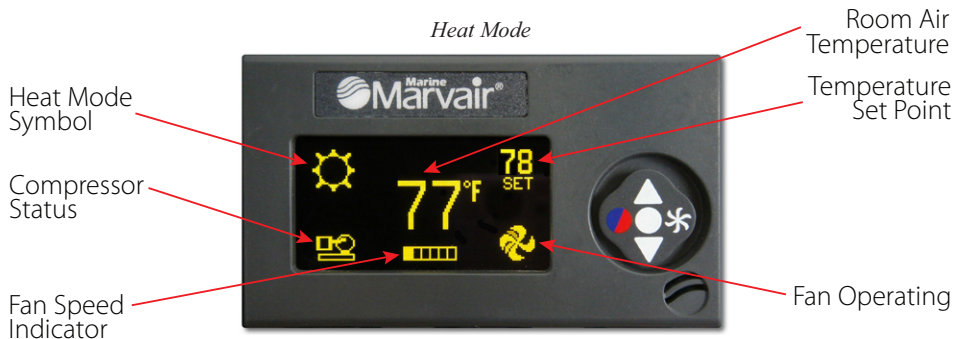

Automatic Mode

To select automatic mode, tap the mode select button to scroll through the symbols in the top left of the display until the automatic mode symbol appears. In this mode, the system will automatically maintain room temperature. Set the desired room temperature by tapping the up or down joystick button. When the system is operating, the appropriate symbol will appear in the lower left corner.

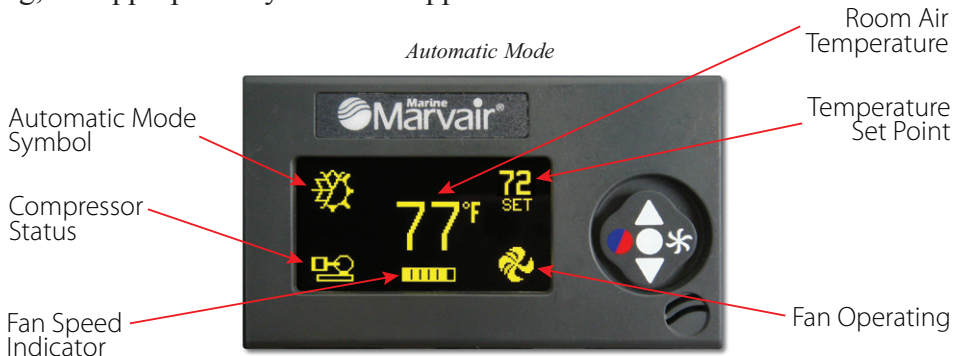

Marvair® Reverse Cycle Air Conditioners

Moisture Mode

Select this mode to help control humidity in the room while the room is unoccupied. To select moisture mode, tap the mode select button to scroll through the symbols in the top left of the display until the moisture mode symbol appears. When the moisture mode is selected, the fan will run in low speed for 30 minutes. After 30 minutes, the compressor will start and run in the cooling mode until the room temperature drops (2°C), but no longer than one hour. This cycle will be repeated every 6 hours. *Note: the Dehumidification mode will not start if the room temperature is less than 70°F (20°C).*

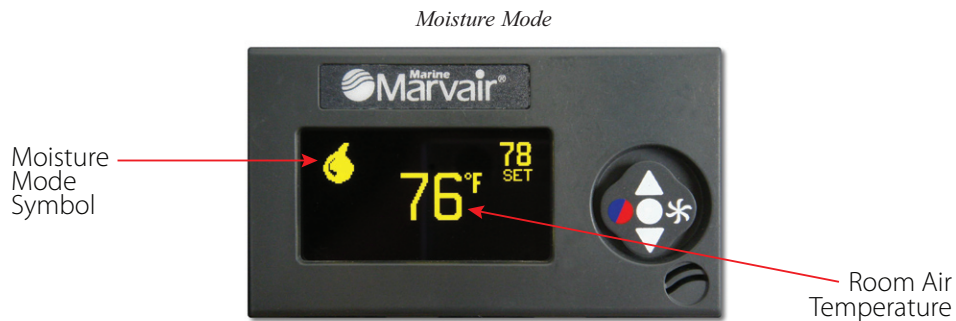

Operating the Fan

Fan speed may be controlled automatically by room temperature or manually. Tap the joystick fan button to cycle through fan speeds and automatic operation. Manually selected fan speed is indicated with the M showing before the speed indicator. When the fan is automatically controlled, the M is not present. The fan may be controlled in the cool, heat, automatic modes as well as in the “Off” state to circulate room air. In the “Off” state, the fan speed can be adjusted and turned off if desired.

Manual fan speed operation is not available when the compressor is not running if the cycle fan option is set. Turn the unit off in this case and then manual fan operation may be used. Manual fan speed operation is also not available in moisture mode.

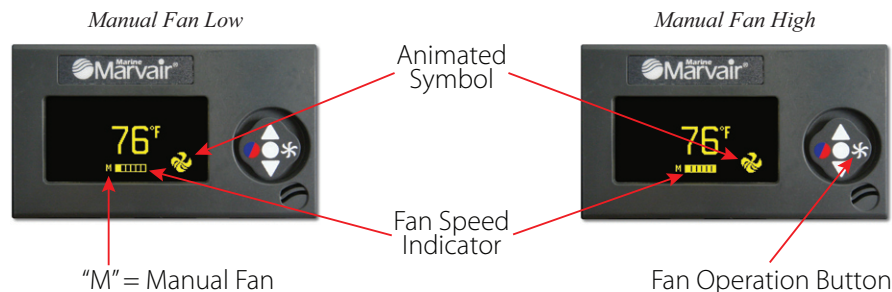

Outside Air Temperature

If the optional outside air temperature sensor is installed, the temperature set point in the upper right of the display will alternate with OAT showing outside air temperature.



Factory Defaults

To revert back to the factory default settings:

With the Thermostat in the OFF setting,

Marvair® Reverse Cycle Air Conditioners

1. Use the joy stick, press in the following sequence: Mode, Up, Down and Mode again.
2. Use the fan button to advance to the Reset Parameters screen. This is the last screen.
3. Use the Up/Down button and select “YES”.

Viewing System Status

In the ON state, press and hold the Mode select button for two seconds. The display will indicate AC line voltage, System current, AC Line frequency, and High and Low pressure switch status and condenser coil temperature if optional sensor is installed.

Failure Codes

The following fault messages will be shown on the display in the event of a failure. Repeated faults are an indication of a problem and should be checked by a qualified service person.

HIGH REFRIGERANT PRESSURE LOW REFRIGERANT PRESSURE
LOW AC VOLTAGE SYSTEM OVER CURRENT
CHECK WATER PUMP AIR SENSOR TROUBLE
LOCKOUT

Program Parameters

There are fifteen programmable parameters with their factory defaults described in this section. The table below defines the parameter descriptions along with the permitted values and default settings.

To enter the program mode first put the unit in the off state. Next press the following sequence of buttons: **Mode, Up, Down, Mode**. Use the fan button to advance to the next parameter and the mode button to go back to the last parameter. Use the up and down buttons to change the parameters value. Exit the program mode when finished by pressing and releasing the On/Off button or wait 60 seconds for the display to exit.

	Description	Default	Value
1	Cycled fan	Continuous	Cycled or Continuous
2	Reverse fan in heat	Reverse	Reverse or Normal
3	System units	°F	°F or °C
4	Display brightness	15	4=Minimum 15=Maximum
5	Screen saver brightness	4	- and 1-8
6	Temperature calibration	0	Ambient +/- 10°F
7	Staging delay	15	5-135 Seconds
8	Failsafe Level	3	Off 1, 2, 3
9	Low AC line detection	Off	Off 75 to 100 (115VAC units) 175 to 200 (220 VAC units)
10	De-Ice time	Off	Off, 30 to 90 seconds
11	Pump sentry	Off	Off, 100°F to 150°F (37.8°C to 65.6°C)
12	Cycle pump	Cycle	Cycle or Continuous
13	Electric Heat	No Electric Heat	Electric Heat or No Electric Heat
14	Fan speed 1	30	30-90
15	Fan speed 2	35	30-90
16	Fan speed 3	40	30-90
17	Fan speed 4	45	30-90
18	Fan speed 5	55	30-90
19	Fan speed 6	85	30-90
20	Reset Parameters	No	No or Yes

Marvair® Reverse Cycle Air Conditioners

Parameter Description:

1. **Cycled fan:** When set for cycled, the fan will operate on demand. When set for continuous, the fan will always run unless you turn the system off.
2. **Reverse fan in heat:** Fan speed will increase as the room temperature rises if this parameter is set for reverse. If set for normal, fan speed will decrease as room temperature rises. This parameter only works in heat mode and the fan must be set for automatic operation.
3. **System units:** Degrees Fahrenheit (°F) or degrees Celsius (°C) can be selected
4. **Display brightness:** Display brightness can be set from 4 to 15 to suit room lighting. Brightness will change as the number is changed.
5. **Screen saver brightness:** If set for (-) then a single bar (-) will blink sequentially in the four corners of the display. Number values from 1 to 8 can be set to suit room brightness and the unit will operated as described in the screen saver section.
6. **Temperature calibration:** This parameter allows the user to calibrate the room air temperature sensor. The room temperature will be displayed and can be adjusted +/-10 °F or +/-5°C
7. **Staging delay:** The compressor staging delay is provided for multi system installations where more than one system is operating from the same power source. Set the Staging delays at different intervals so only one compressor starts at a time when power is applied.
8. **Fail safe level:** There are four fail safe levels the controller can be set to operate: OFF, 1, 2, and 3. The default is 3.

Off	Do not detect or display any faults except air sensor failure
1	The controller will detect a fault but will not display the fault Operation will stop until the fault is cleared.
2	The controller will detect and display all faults. Operation will stop until the fault is cleared.
3	The controller will detect and display all faults. Operation will stop until the fault is cleared. After 4 faults the controller will LOCKOUT and prevent further operation

If LOCKOUT appears in the display, the unit must be turned off then on again with the Off/On button.

9. **Low AC line detection:** When set, if the AC line voltage remains below the set value, the system will follow the action set by the failsafe level.
10. **De-Ice time:** When set, the system will perform the evaporator de-icing program.
11. **Pump sentry:** This system can be equipped with an optional sensor to monitor the condenser coil temperature. If the temperature exceeds the set value, the failure will be handled according to the failsafe level. This failure will prompt the user to CHECK WATER PUMP. Plug the sensor into the Outside jack. Outside air temperature is not available when this option is used.
12. **Cycle pump:** When set for cycle, the pump will run on demand. When set for continuous, the pump will run continuously when the system is on.
13. **Electric heat/ No electric heat:** Set this parameter only if the system is equipped with an electric heater. *If the heater current will exceed 10 Amps, a contactor must be connected to the valve output to use this feature.*

Marvair® Reverse Cycle Air Conditioners

14-19. Fan speed 1-6: These parameters are used to optimize fan performance and should *be changed only by qualified service personnel.*

20. Reset parameters: To reset all parameters to factory defaults, select YES and then exit the program mode by pressing the joystick center button. The display will show EEPROM RESET then show the room temperature in the off mode.

Specifications

Set point range	55°F to 85°F (12.7°C to 29.4°C)
Ambient temperature range displayed	5°F to 150°F (-15°C to 65.5°C)
Sensor accuracy	2°F at 77°F (1.2°C at 35°C)
Low voltage limit 115 VAC units	75VAC
Low voltage limit 230 VAC units	175VAC
Line voltage limit	250VAC
Frequency	50 or 60 Hz
Fan output MAX	6 Amps
Valve output MAX	10 Amps
Pump output MAX	¼ HP at 115 VAC ½ HP at 230 VAC
Compressor output	1HP at 115 VAC 2HP at 230 VAC
Minimum operating temperature	0°F (-17.8°C)
Maximum operating temperature	180°F (82°C)
Maximum RH conditions	99% Non-condensing
Maximum length of the display cable	75 Feet (22.86 m)
Maximum length of the Outside air sensor cable	50 Feet (15.24 m)

Marvair® Reverse Cycle Air Conditioners

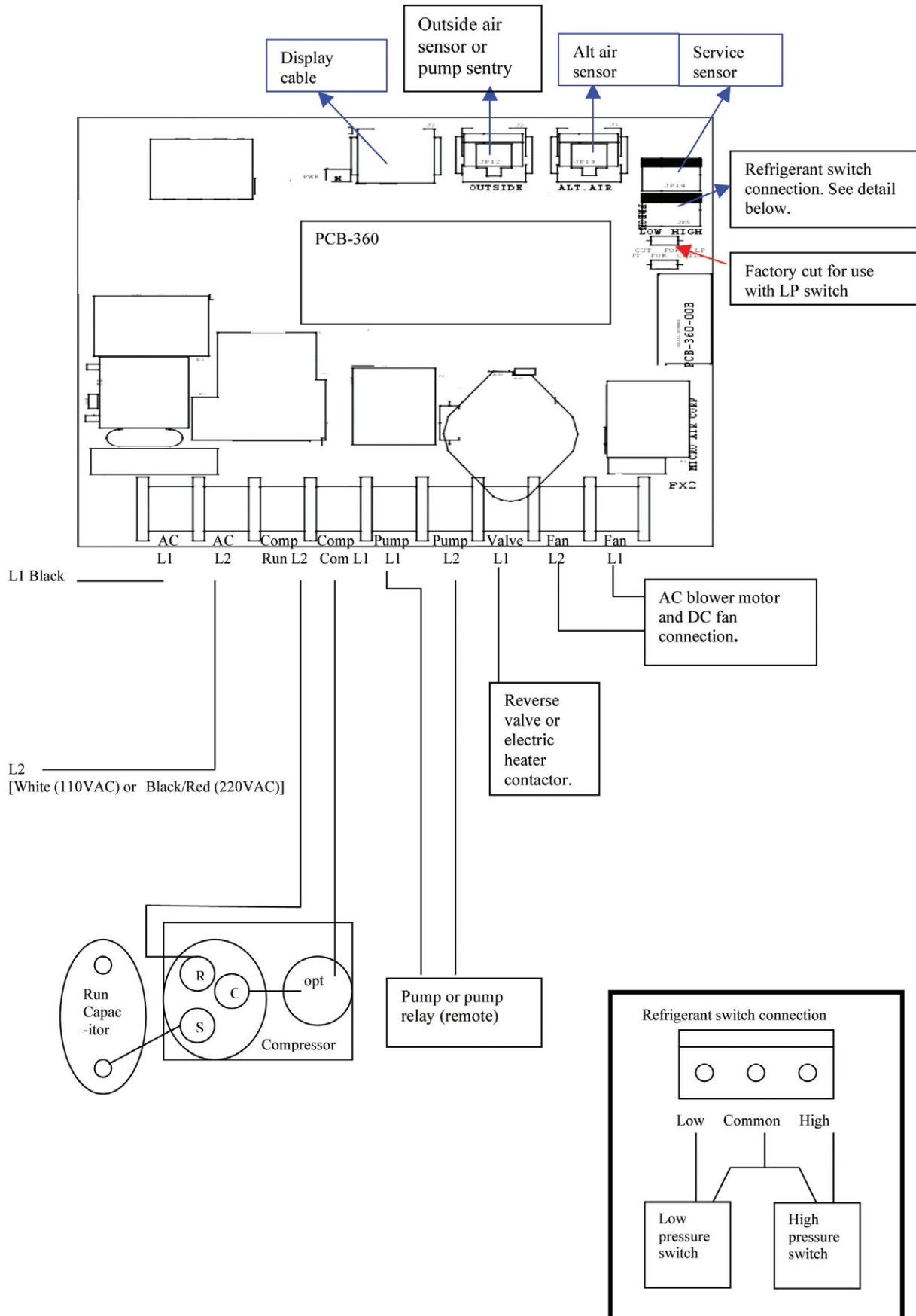

Marvair® Reverse Cycle Air Conditioners

4.2 Instructions for the MachAir I Controller

The Marvair® reverse cycle air conditioner utilizes the MachAir™ 1 Controller and Display which has a universal power supply that operates on 115V or 240V and 50 or 60 Hz AC power.

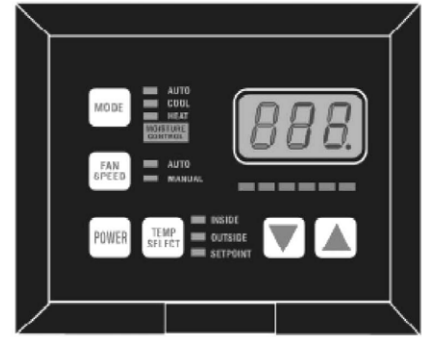

Standard Features

- User friendly 6 button display panel requires no manual for basic operation
- Five-volt logic and micro controller located on the display
- 3-digit, 7-segment display panel indicates degrees Fahrenheit or Centigrade
- Paintable Face Plate Cover with recess for matching wall covering insert
- Automatic fan speed reduction as set point is approached
- Six (6) programmable manual fan speeds
- AC voltmeter to protect valuable electrical components
- 16 programmable parameters for custom installations
- High and low refrigerant pressure switch inputs
- Moisture Mode for controlling relative humidity
- De-Icing cycle to prevent evaporator coil icing
- Universal AC Power Supply
- Non-volatile memory retains settings without batteries
- Programmable display brightness control for night use

Optional Features

The following optional items can be added by plugging the device into the appropriate jack and making the necessary programming changes.

- Outside Air Temperature Sensor - No Programming Necessary
- Alternate Air Temperature Sensor - No Programming Necessary
- Custom Paintable Display Panels
- Pump Guard Water Sensor - Program Setting of P-8 is Required

This manual is intended to provide the information necessary to ensure proper installation and operation of MachAir Controller. Improper installation and/or misunderstood operating parameters will result in unsatisfactory performance and premature failure of the MachAir Controller.

Your Marvair® reverse cycle air conditioner has a solid state control board located in the electrical box on the unit. This control board is compatible for use with either the o-LED display or the MachAir I display. The board is configured at the factory for the o-LED display. To use the board with the MachAir I display, two pins must be moved on the control board. The pins should be removed by hand; do not use pliers or a screw driver to remove the pins.

Marvair® Reverse Cycle Air Conditioners

1. Turn off the power to the Marvair® unit at the breaker.
2. Remove the cover to the electrical box.
3. Carefully pull the two clips on JP11 & JP9 and move them to the position for use with the MachAir I display. Be careful not to bend the pins.
4. Replace the cover to the electrical box.
5. Turn the breaker on to power the unit. Proceed with the programming.

Pin configuration for use with the o-LED display/controller.

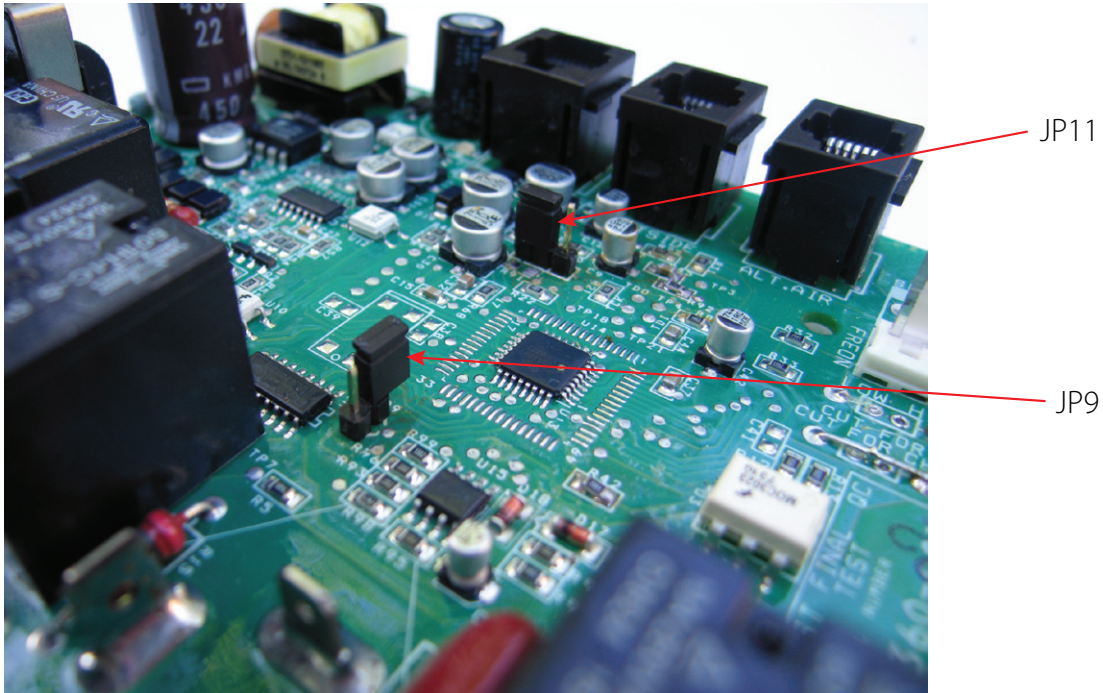

Pin Configuration for use with the MachAir I display/controller

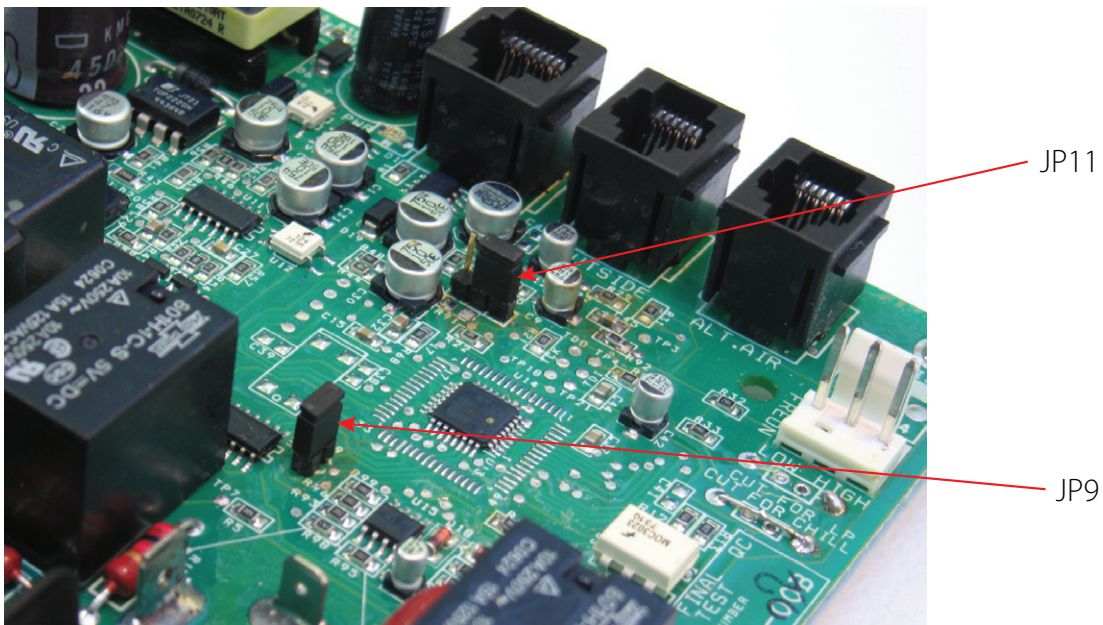

Marvair® Reverse Cycle Air Conditioners

Basic Operation

POWER BUTTON Press the **POWER button** once to toggle the unit to the “ON” mode. Press the **POWER button** again to toggle the unit to the “OFF” mode.

FAN SPEED BUTTON Press and release the **FAN SPEED button** to advance from “AUTO” to “MANUAL” fan operation. Press and release to increase the manual fan speeds, to settings “1 through 6”. Press and release again, returns it to the “AUTO” fan mode. The selected fan mode is identified by the LED’s for “AUTO” and “MANUAL”.

UP BUTTON Momentarily press and the set point will appear in the temperature display. The set point increases one degree each time the **UP arrow button** is pressed and released.

DOWN BUTTON Momentarily press and release to display the set point. The set point is decreased one degree each time the **DOWN arrow button** is pressed and released.

MODE BUTTON The **MODE button** is used to select one of 4 Operating Modes. Press and release to advance to the next mode. Continue to press and release until the desired Operating Mode is reached. The mode selected is indicated by the Mode LED.

TEMP SELECT BUTTON Press and release to view the inside (supply) air temperature, outside (return) air temperature or set point. The appropriate LED will be lit indicating that temperature is being displayed.

THREE DIGIT DISPLAY The inside (supply) temperature is displayed whenever the control is turned on. The display provides a readout of the inside air temperature which is located in the supply duct.

HEAT MODE LED The “HEAT” mode LED is lit when Heating is selected.

COOL MODE LED The “COOL” mode LED is lit when Cooling is selected.

AUTO LED The “AUTO” mode LED is lit when the Automatic Heating or Cooling mode is selected. The control will automatically switch to heating or cooling when this mode is selected.

MOISTURE CONTROL LED The “MOISTURE CONTROL” LED is lit when Moisture Control is selected.

MANUAL FAN LED The “MANUAL” Fan Speed LED is lit when the fan speed has been manually selected.

AUTO FAN LED The “AUTO” Fan Speed LED is lit when the fan speed has been automatically selected.

FAN SPEED BAR GRAPH There are six (6) individual fan speed LED’s. Each LED represents one (1) fan speed. The lowest fan speed setting is indicated by illuminating the first LED. The highest fan speed setting is indicated by illuminating all six LED’s.

LED The system operating status (Compressor On or Off) is indicated by turning on the right most decimal point in the 3 Digit Display.

Marvair® Reverse Cycle Air Conditioners

System Overview

Press the POWER button once to engage the system. The Display indicates room temperature when the system is on and the display is blank when the system is off.

Press and release the MODE Button until the desired Mode LED is illuminated.

Set the desired room temperature by pressing the Up or Down arrow buttons. The set point can viewed by momentarily pressing and releasing the Up or Down arrow buttons.

Fan speed operation is automatic allowing fan speed to decrease as room temperature is approached. The fan speed decreases as the set point is approached. The fan will operate at low speed when the set point is satisfied. Manual fan speeds can be selected by pressing and releasing the FAN SPEED button to select the desired manual fan speed. The fan will operate at the speed selected and will not change speeds with room temperature.

The fan can be programmed to cycle on and off with demand, allowing the fan to run only when cooling or heating is required. Normally the automatic fan speed operation is reversed in the heating mode, however, the fan can be programmed to operate the same as in the cooling mode.

Normal Heating or Cooling Cycle

Select COOL mode and cooling only will be provided. The cabin temperature will be maintained within 2°F of the set point. Select HEAT mode and heating only will be supplied. The cabin temperature will be maintained within 2°F of the set point.

Select AUTO and either heating or cooling will be supplied when it is required. While in the automatic mode the controller will maintain the set point within a 2°F temperature variation. A four degree swing is required to cause the unit to shift to the opposite mode. Once in a given mode, heating or cooling, the controller will maintain a 2 degree differential.

When the heating or cooling demand is satisfied, the compressor cycles off and the automatic fan returns to low speed. The fan speed will remain constant if MANUAL Fan Speed had been selected.

Reversing Valve Operation

The reversing valve is toggled to the opposite mode (for pressure equalization) when heating or cooling is required to reduce the compressor's starting requirements and the electrical power surge. The valve will only toggle to the opposite mode when a cooling or heating cycle is called for and if the system has been off for less than seventy-five (75) seconds. The valve will also toggle if a cycle is interrupted from the display panel by pressing the POWER button On/Off, or by changing the set point. Unnecessary valve toggling has been limited to reduce reversing valve noise. Valve toggling can be totally eliminated by programming the minimum compressor staging delay at seventy-five (75) seconds or greater.

Power on reset, which occurs when the system is powered up, will always initiate a valve toggle.

Controller Memory

The MachAir Controller has non-volatile memory which requires no batteries or any form of backup power. When power is lost, the operating parameters are retained indefinitely. When power is restored, the controller resumes operation as last programmed. All operating and programming parameters are entered into non-volatile memory instantly and are retained indefinitely.

Marvair® Reverse Cycle Air Conditioners

Operator Controls and Display Panel

1. **POWER BUTTON** The **POWER** button is used to toggle between the **On** and **Off** modes. Press the **POWER** button once to toggle the unit to the **On** mode. Press the **POWER** button again to toggle the unit to the **Off** mode.
2. **FAN SPEED BUTTON** Press and release the **FAN SPEED** button to advance from **AUTO** to **MANUAL** fan. Press and release the **FAN SPEED** button to advance the manual fan speeds, from 1 through 6. Press and release again to return to the **AUTO** fan mode. The selected fan mode is indicated by the **AUTO** and **MANUAL** fan LED's.
3. **UP ARROW BUTTON** Momentarily press the **UP** arrow button and the set point will appear in the temperature display. Press and release the **UP** arrow button to increase the set point one degree. The set point is increased by one degree each time the **UP** arrow button is pressed and released. The highest set point allowed is 85° Fahrenheit. The **UP** arrow button is used in conjunction with the **DOWN** arrow button to display the outside air temperature when the control is on. The **UP** arrow button is also used to increase program values in the program mode.
4. **DOWN ARROW BUTTON** Momentarily press and release the **DOWN** arrow button to display the set point. Press and release the **DOWN** arrow button to decrease the set point. The set point is decreased one degree each time the **DOWN** arrow button is pressed and released. The lowest set point allowed is 55° Fahrenheit. The **DOWN** arrow button is used in conjunction with the **UP** arrow button to display the outside temperature when the control is on. The **DOWN** arrow button is also used to reduce program values in the program mode.
5. **MODE BUTTON** The **MODE** button is used to select one of the four operating modes. Press and release the **MODE** button and the controller will advance to the next mode. Continue to press and release the **MODE** button until the desired operating mode is reached. The mode selected is indicated by the **MODE** LED, i.e., **COOL**, **HEAT**, **AUTO** or **MOISTURE CONTROL**.
6. **TEMP SELECT BUTTON** Press and release the **TEMP SELECT** button to view inside air temperature, outside air temperature or the set point. The appropriate LED, **INSIDE**, **OUTSIDE** or **SET POINT** will be illuminated indicating which temperature is being displayed. If no outside air sensor is installed three (3) dashes will appear in the Three Digit Display.
7. **THREE DIGIT SEVEN SEGMENT DISPLAY** The inside air temperature is displayed in the window whenever the control is turned on. The three digit 7 segment display provides a readout of the inside air temperature which is located in the face plate. An optional alternate air sensor is available for installations that can not use the face plate sensor.

The display also indicates program information, fault codes and outside air temperature when the optional alternate air sensor is installed.

The display momentarily indicates the **SET POINT** when the **UP** or **DOWN** arrow button is pressed.

When the control resumes operation after a power interruption all the display LED's will turn on for one second. This is a normal operating condition and is referred to as "Power On Reset".

8. **HEAT MODE LED** The **HEAT** mode LED will be illuminated when the Heating Mode has been selected. The **HEAT** mode LED is also illuminated when optional electric heat is installed and the

Marvair® Reverse Cycle Air Conditioners

Heating Mode has been selected. Electric heater status, On or Off, is indicated by the right most decimal point (see Item 18).

9. **COOL MODE LED** The **COOL** mode LED will be illuminated when the Cooling Mode has been selected.
10. **AUTO LED** The **AUTO** LED is illuminated when the Automatic Heating or Cooling Mode has been selected. The controller will automatically switch to Heating or Cooling when this mode is selected.
11. **MOISTURE CONTROL LED** The **MOISTURE CONTROL** mode LED is illuminated when Moisture Control has been selected. This mode is used to control humidity during periods when the vessel is unoccupied.
12. **MANUAL FAN SPEED LED** The **MANUAL** Fan Speed LED will be illuminated when one of the six (6) Manual Fan Speeds has been selected.
13. **AUTO FAN SPEED LED** The **AUTO** Fan Speed LED is illuminated when Automatic Fan Speed is functioning.
14. **FAN SPEED BAR GRAPH** There are six (6) individual Fan Speed LED's in the Fan Speed Bar Graph. Each LED represents one (1) Fan Speed. Low Fan Speed **1** is indicated by illuminating the first LED. High Fan Speed **6** is indicated by illuminating all six (6) LED's. Any of the six (6) Fan Speeds available are displayed by the illuminated corresponding number of LED's.
15. **INSIDE LED** The **INSIDE** LED is illuminated when the Inside Air Temperature is being displayed.
16. **OUTSIDE LED** The **OUTSIDE** LED is illuminated when the outside air temperature is displayed.
17. **SET POINT LED** The **SET POINT** LED is illuminated when the Set Point is displayed.
18. **COMPRESSOR LED** The system operating status (Compressor On or Off) is indicated by turning on the right most decimal point in the 3 Digit Display.

Dual Button Functions

UP & DOWN ARROW BUTTONS Press the **UP** and **DOWN** arrow buttons together and the outside air temperature will be displayed, providing the Optional Outside Air Temperature Sensor has been installed. No programming is required. Press the **UP** and **DOWN** arrow buttons simultaneously, while in the program mode, to set new custom programming defaults.

POWER BUTTON & DOWN ARROW BUTTON Simultaneously pressing the **POWER** button and the **DOWN** arrow button while viewing the Service Fault History Log clears the fault History Log.

Special Button Functions

Special button functions are implemented by pressing and holding a particular button while the control's AC power is turned on.

1. **Service History Log** View the service history log by pressing and holding the **MODE** button while turning on the AC power. Exit the service history log by pressing the **POWER** button once. Clear the

Marvair® Reverse Cycle Air Conditioners

service history log by simultaneously pressing the **POWER** button and the **DOWN** arrow button.

2. **Self Test Mode** Press and hold the **POWER** button while AC power is applied to enter the self test mode. The self test mode is used to diagnose problems and to test the air conditioning system.
3. **View Hour Meter** To view the compressor hour meter, press and hold the **DOWN** arrow button while applying AC power. Maximum recorded time is 10,000 hours. The hour meter stops at maximum (10,000 hrs) and can only be reset by the Manufacturer.

Modes of Operation

Off Mode

When the controller is in the **Off Mode**, all control outputs are turned off. Program parameters and user settings are saved in a non-volatile memory. The program mode can only be accessed from the **Off Mode**.

On Mode

When the controller is in the **On Mode**, power will be supplied to the appropriate control outputs and the display will indicate the current state of operation. The operating and program parameters resume based on those stored the last time the unit was operating.

Cool Only Mode

When the **COOL** LED is on, only the Cooling systems are selected and operated as required. When the temperature drops below the set point, the system will not automatically switch to the Heating Mode.

Cooling only is available for customers that do not want automatic Cooling and Heating operation. Systems without reverse cycle heating can have an optional electric heater installed should heating be required.

Heat Only Mode

When the **HEAT** LED is on, only the Heating systems are selected and operated as required. Should the temperature rise above the set point, the system will not automatically switch to the Cooling mode. Heating only is supplied for customers that require the system to not automatically switch from the Heating to the Cooling mode.

Automatic Mode

When the **AUTO** LED is on, either Heating or Cooling are supplied as required. The **HEAT** and **COOL** LED's will be illuminated according to the mode required. When the system requires compressor operation for Heating or Cooling the right most decimal point will turn on when the compressor is on.

Temperature in a given mode will be maintained at two degrees Fahrenheit (2°F), however, a four degree difference is required to allow the controller to change modes. Once in a new mode, the temperature will remain within two degrees Fahrenheit (2°F) of the set point.

Moisture Control Mode

While in the on mode, press the **MODE** button until the **MOISTURE CONTROL** mode LED is illuminated. Every four (4) hours, the fan is started and air is circulated for thirty (30) minutes. During this time the air temperature is sampled and entered into memory. The cooling cycle is started and continues until the temperature is lowered 2°F. The compressor is allowed a maximum of one hour running time to

Marvair® Reverse Cycle Air Conditioners

reach the desired temperature. Four (4) hours after the temperature is satisfied on the compressor the cycle will be repeated. The right most decimal point is illuminated while the compressor is running.

Fan Speed Modes

Auto Fan Speed Mode

The controller has six automatic fan speeds available. Speed **6** is high, **3** is medium and **1** is low or the slowest speed. **AUTO** Fan Speed mode allows the controller to determine the required fan speed based on room temperature. The closer the room temperature is to the set point, the slower the fan will run. This permits a balance between the most efficient temperature control and the slower/quieter fan speeds. Automatic Fan Speed operation is the **factory default**, however, **MANUAL** Fan Speed mode is available.

Manual Fan Speed Mode

The controller has six automatic fan speeds available. Speed **6** is high, **3** is medium and **1** is low or the slowest speed. **MANUAL** Fan Speed mode allows the user to select and maintain the desired fan speed manually. When a **MANUAL** Fan Speed has been selected, the Fan Speed Bar Graph will indicate the speed selected by the number of LED's illuminated. Select Fan Speed **3**, for example, and the first three LED's in the Fan Speed Bar Graph will turn on. **MANUAL** Fan Speed mode is sometimes preferred when room temperature is constantly changing due to varying heat loads.

Program Mode

Program Mode Overview

The program mode is used to adjust the systems operating parameters to suit the particular needs of individual users. The program mode is also used to tailor the air conditioning system for the most efficient operation within an installation. Installation variables such as ducting, sensor location and system layout effect the perceived operation of the overall system. The program mode allows the system to operate as efficiently as possible under all conditions. The controller is shipped with factory programmable default settings which are stored in permanent memory and can be recalled at any time.

Warning

Severe electrical disturbances can sometimes upset the controller operating sequences. Operator confusion related to program parameters can also cause, what seem to be, operational problems. Whenever there is any doubt as to the proper operation of the controller, Factory Default Parameters, should be re-initialized.

Entering Program Mode

The program mode can only be entered from the Off Mode. From the Off Mode and in the following order, press the **TEMP SELECT**, **UP** arrow, **DOWN** arrow and **TEMP SELECT** buttons. These buttons have to be pressed and released in the order given. The numerals "85" which represent the high Fan Speed limit, appear in the display. The "85" is followed by the characters "P1" followed again by the parameter setting ("85"). **P1** represents the first programmable parameter. The controller is now in the program mode. Exit the program mode, to the Off Mode, by pressing and releasing the **POWER** button.

NOTE: The controller will exit the program mode and return to the Off Mode if no programming is attempted for one (1) minute.

Marvair® Reverse Cycle Air Conditioners

Restore Memorized Default Settings

The memorized default settings can be restored by entering the program mode and setting P-16 to rSt. Exit the program mode and the software version number appears in the display. The memorized default settings are restored and the controller returns to the Off Mode. The software version number is always displayed when you exit the program mode.

Increment from one parameter to the next by pressing and releasing the **MODE** button while in the program mode. Use the UP arrow and DOWN arrow buttons to change the program parameter values. The programmable parameters range from P-1 through P-16.

Up and Down Buttons

The **UP** arrow and **DOWN** arrow buttons are used to select the data or set the desired limits for the parameters being programmed. This method is followed throughout the program mode, however, special instructions are included for individual functions that require them.

Exiting the Program Mode

There are two methods to exit the program mode. Press the **POWER** button and the controller will return to the Off Mode. Not pressing any buttons or attempting any program changes for sixty (60) seconds will allow the controller to exit the Program Mode to the Off Mode. Any programming changes that were made while in the program mode will be memorized and put into operation when the program mode is exited and the controller is returned to the On Mode.

Marvair® Reverse Cycle Air Conditioners

Programming

Programmable Parameters

There are sixteen (16) programmable parameters with their Factory Default Settings listed in this section. The table below indicates what these parameters are, along with the permitted values and the original Factory Default Settings.

Program Number	Description	Default	Range
P-1	High Fan Speed Limit (arbitrary units)	85	56 to 85
P-2	Low Fan Speed Limit (arbitrary units)	50	30 to 55
P-3	Compressor Staging Time Delay	15	5 to 135 seconds
P-4	Temperature Sensor Calibration	0	Ambient \pm 10°F
P-5	Failsafe Modes and Mnemonic High refrigerate Pressure (HPF) Low refrigerate Pressure (LPF) Low AC Line Voltage (LAC)	3 = 4 Failures With 90 Second Restart Delay. Manual Reset is Required	Off 1 = Continuous No Display 2 = Continuous With Display 3 = 4 Failures Reset Required
P-6	Low AC Voltage Cut-Off	85 VAC (115 vac) 185 VAC (230 vac)	Off - 75 to 100 (115 vac Units) Off - 175 to 200 (220 vac Units)
P-7	De-Icing Cycle	0	0 = Off 1 to 3 Minutes
P-8	Pump Sentry - Protects Pump and Compressor From Loss of Water	Off	OFF ON = Select 100°F to 150°F
P-9	Display Brightness Control	13 = Maximum	4 = Low 13 = Maximum
P-10	Display °Fahrenheit or °Centigrade	°F	°F = Fahrenheit Displayed °C = Centigrade Displayed
P-11	Cycle Pump With Compressor or Continuous Pump	OFF = Cycle With Compressor	OFF = Cycle With Compressor ON = Continuous Pump
P-12	Reverse Fan Speeds During Heating Mode	rEF = Reversed	nor = Normal Fan Operation rEF = Reversed Fan in Heating
P-13	Continuous Fan or Cycle Fan With Compressor	con = Continuous Fan Operation	CYC = Cycle Fan w/Compressor rEF = Reversed Fan In Heating
P-14	Reverse Cycle Heating or Electric Heat Only Option Installed (Cooling Only Units)	nor = Reverse Cycle Heating	nor = Reverse Cycle Heating ELE = Electric Heater Installed
P-15	Fan Motor Type Selection - Shaded Pole or Split Capacitor	SP = Shaded Pole	SP = Shade Pole Fan Motor SC = Split Cap. Fan Motor (NOTE: All Marvair® units use a split capacitor motor. Select SC.)
P-16	Reset Memorized Programming Defaults	nor = Normal	rSt = Reset Defaults

Should any programming problems or confusion occur, reset the Memorized Default Settings by entering the program mode and setting P-16 to rSt.

Marvair® Reverse Cycle Air Conditioners

P-1 High Fan Limit

The upper fan speed limit can be changed to suit different motors and operating conditions. The **high fan limit** is adjusted with the system installed and operational. The range of values are 56 through 85 and represent arbitrary units. Setting a higher number, results in a higher fan speed, setting a lower number, lowers the fan speed. Use the **UP** and **DOWN** arrow buttons to select the desired fan speed limit. The factory default is eighty-five (85).

P-2 Low Fan Limit

The **low fan limit** determines the lowest output allowed for the low fan speed. The range of values for the low fan speed are 30 through 55, in arbitrary units. Use the **UP** and **DOWN** arrow buttons to select the desired low fan speed limit. Setting a higher number, results in a higher fan speed, setting a lower number, lowers the low fan speed limit. The factory default setting is fifty (50).

Once the high and low fan speed limits are set, the unit will automatically readjust the four (4) remaining fan speeds to produce six (6) equally spaced fan speeds in both the **AUTO** and **MANUAL** fan speed modes.

P-3 Compressor Staging Time Delay

NOTE: This feature is not being used on the Marvair® reverse cycle air conditioners.

The **compressor staging relay** is provided for installations where more than one system is being operated from the same power source. Setting the staging delays at different intervals allows only one compressor to start at a time. The units should be staged at least five (5) seconds apart. The minimum delay is five (5) seconds and the maximum is one hundred thirty-five (135) seconds. The factory default setting is fifteen (15) seconds.

P-4 Temperature Calibration

Use this feature to calibrate the air sensor within a range of \pm ten (10)°F. Enter the program mode and the ambient temperature appears in the display. Use the **UP** and **DOWN** arrow buttons to select the desired offset. The temperature in the display will increase or decrease according to the offset programmed. The factory default setting is zero.

P-5 Fail-Safe Level

The system can be configured for one of four fail-safe levels. Selecting **OFF** turns off all fail-safe protection and mnemonic display codes. Level **ONE (1)** shuts down the system, allows the system to restart after a 90 second delay and displays no failure code. Level **TWO (2)** shuts down the system but allows continual restarts after the 90 second delay and displays the appropriate mnemonic failure code. Level **THREE (3)** operates the same as level **TWO (2)** with the addition of a system shutdown after four (4) consecutive failures. Manual reset is required to restart the system.

P-6 Low Voltage Cut-Off

The controller can be programmed to protect the system against sustained low AC line voltage conditions. The compressor will be shut down and “**LAC**” flashed in the display if the line voltage goes below the programmed value for more than ten (10) minutes. Programmable values are 75 VAC to 100 VAC for 120 volt units and 175 VAC to 200 VAC for 220 volt systems. The factory default is 85 VAC for 120 volt units

Marvair® Reverse Cycle Air Conditioners

and 185 VAC for 220 volt systems. **NOTE:** Low Voltage Protection can be turned off by programming **OFF** instead of selecting a voltage value.

P-7 De-Icing Cycle

The controller is equipped with a De-Icing Cycle to prevent ice build up on the evaporator coil during extended periods of cooling operation. Installation variables such as grille sizes, length of ducting, insulation “R” factors and ambient temperatures determine the cooling run time required to achieve the set point. Customer usage may substantially increase run times by operating the system with the hatches and doors open. Programming an unrealistic set point (55°F) and leaving the salon door open will usually cause the evaporator to ice up on warm muggy days.

De-Icing is accomplished by switching the reversing valve into the **HEAT** mode while the system is cooling. The valve will remain energized for the programmed cycle time. The cycle is programmable from OFF through a period of 3 minutes. The factory default setting is OFF.

P-8 Optional Pump Sentry

NOTE: This feature is not being used on the Marvair® reverse cycle air conditioners. The controller can be equipped with an optional temperature sensor that is used to monitor the heat exchanger temperature. The sensor is plugged into the outside air sensor jack and programmed for a temperature between 100 and 150°F depending on water temperature and the system type. When the heat exchanger temperature rise above the programmed value the pump and compressor are shut down and “PPP” is flashed in the display. The factory default is OFF, no Pump Sentry installed.

P-9 Display Brightness Control

The display brightness can be adjusted to suit ambient cabin lighting conditions. The allowed settings are four (4) to thirteen (13) the brightest. Typically a dark cabin will require a setting of four or five. A very bright cabin will require a setting of twelve or thirteen. The factory default setting is thirteen (13).

P-10 Fahrenheit or Celsius Selection

The unit can be programmed to display either Fahrenheit or Celsius. Programming °F displays degrees Fahrenheit and programming °C, displays degrees Celsius. The factory default setting is °F, Fahrenheit. When degrees Celsius (°C) is selected the readings are displayed in tenths, i.e. 22.2°C.

P-11 Cycle Pump With Compressor

To increase pump life and conserve electricity the pump can be programmed to cycle on and off with the compressor. The pump can also be programmed to operate continuously whenever the system is on. To program the pump for continuous operation, turn “P-11” **ON**. The factory default setting is **OFF**, which cycles the pump with the compressor.

P-12 Reverse Automatic Fan Speeds During Heating

The automatic fan speeds can be reversed during the heating mode to improve heat output in cooler climates. The fan speed is decreased as the temperature spread increases. The fan will speed up as the set point is approached. Lowering the fan speed when the cabin is cold increases head pressure and raises the supply air temperature. Increasing the fan speed as the set point is approached also reduces unnecessary high pressure faults. The fan switches to low speed when the set point is satisfied and the compressor

Marvair® Reverse Cycle Air Conditioners

cycles off. The fan can be programmed to operate the same as in cooling by programming “P-12” **nor** which represents normal fan operation during reverse cycle heating. The factory default setting is **rEF**, which reverses the automatic fan speeds during heating.

P-13 Cycle Fan With Compressor

The fan can be programmed to run continuously when the system is on or can be allowed to cycle with the compressor. When cycled with the compressor, the fan will operate only when heating or cooling is called for. To cycle the fan with the compressor select **CYC** which stands for cycle the fan with the compressor. To operate the fan continuously select **con** which represents continuous fan operation. The factory default setting is **con** continuous fan operation when the system is on.

P-14 Reverse Cycle or Electric Heat

Electric heat is not currently available on Marvair® units.

IMPORTANT

P-15 Fan Motor Selection

There are two basic fan motor types, shaded pole and split capacitor. Each motor reacts differently to speed control and each motor requires different timing for optimum fan speed control. The default setting is “**SP**” which selects the shaded pole motor type, however, “**SC**” should be selected if a split capacitor type motor is used in the system. The Marvair® direct expansion systems are supplied with a split capacitor type fan motor so “**SC**” should be selected. The factory default setting is “**SP**” for the shaded pole type fan motor. **IMPORTANT:** The factory default setting “**SP**” should not be used on the Marvair® reverse cycle air conditioners.

P-16 Reset Memorized Defaults

The default programming parameters can be reset by entering the program mode and selecting “**rST**”. This will restore the programmable parameters to the values selected when the system was shipped.

Why Memorize New Defaults?

Once the desired programming changes have been made and the system tests satisfactorily, your work can be saved as the **new factory defaults**. Your new defaults are initiated by **simultaneously** pressing and releasing the **UP** and **DOWN** arrow buttons prior to exiting the **program mode**. New defaults can be initialized at any time by entering the program mode and following the above instructions. Once **new defaults** have been initialized the control will revert back to the new defaults whenever factory defaults are restored as previously described in “**P-16**”.

Fail-Safe and Fault Handling Codes

When a fault is detected the controller will display one of the following Mnemonic fault codes:

HPF	Indicates high Refrigerant pressure, 15 second delay, Ignored in HEAT mode.
LPF	Indicates low Refrigerant pressure. There is a ten minute charge time delay.
LAC	Indicates low AC line power
AAA	Indicates failed air sensor. Unit will not run until repaired.
PPP	Indicated the water pump has failed.

Marvair® Reverse Cycle Air Conditioners

Fail-Safe

There are four levels of fail-safe protection including the fail-safe **OFF** mode. Level **1** monitors the sensors, takes appropriate action and allows continuous restarts after a 90 second delay and **does not display the fault code**. Level **2** works the same as Level **1**, however, the appropriate fault code mnemonic is displayed during the time-out between restarts. Level **3** is identical to Level **2** with the inclusion of a three successive failures lockout routine. After four (4) consecutive failures the system is shutdown and a manual reset is required.

Lockout

Lockout occurs if “P-5” is programmed for Level **3** and four consecutive faults are detected within a heating or cooling cycle. Lockout causes the system to shut down and flash the mnemonic fault code. Lockout can only be cleared by turning the unit **OFF** and then **ON** by using the **POWER** button.

Fault Display

When a fault occurs the appropriate mnemonic code is flashed in the display. The flashing mnemonic can be removed from the display by pressing and releasing the **POWER** button to reset the controller. Resetting the controller does not solve the problem caused by the fault.

Fail-Safe Level	Action	Description of Action Taken
OFF	All Protection is Turned Off	FAIL-SAFE PROTECTION LEVELS TURNED OFF: Air Sensor Fault: Heating/Cooling Immediately Suspended; Normal Operation Not Resumed Until Fault is Cleared. Air Sensor Fault Code “Flashing Display” NO OTHER FAIL-SAFE PROTECTION IS PROVIDED.
1	No Mnemonic Fault Code Displayed Continuous 90 Sec. Re-Starts Allowed !	MINIMUM PROTECTION LEVEL All Actions Taken in Fail-Safe Protection Level “0” Plus: In Addition, Continuous 90 Second Compressor Restarts are Allowed. FAULT Mnemonic CODE NOT DISPLAYED NO OTHER FAIL-SAFE PROTECTION IS PROVIDED
2	Display Fault & Shut Down Compressor With Continuous 90 Second Delay Between Starts	INTERMEDIATE PROTECTION LEVEL All Actions Taken in Fail-Safe Protection Levels “0” & “1” Plus: In Addition, The FAULT MNEMONIC CODE Message Will Be Displayed With Continuous 90 Second Compressor Restarts Allowed. NO OTHER FAIL-SAFE PROTECTION IS PROVIDED
3	Display Fault and Require Manual Reset After 4 Failures.	MAXIMUM PROTECTION LEVEL FAULT CODE MESSAGES ARE DISPLAYED and The Appropriate Action is Taken According to The Problem Encountered. After 4 Consecutive Failures Manual Reset is Required.

Marvair® Reverse Cycle Air Conditioners

Specification Notes

Custom cable lengths available on special request in 5 foot increments. Maximum length of display cable is 50 feet. Sensor cable lengths should be limited to 50 feet. The **outside air sensor**, **alternate air sensor** and **condenser coil sensor** are optional items and are not included with the standard control package.

Automated Factory Self Test Program

Self-Test Mode

The controller software contains a self-test program to facilitate factory testing of the entire air conditioning system. Once the **Self-Test** mode is activated, the test cycle will continue until the AC power is interrupted or the On/Off POWER button is pressed once which returns the system to the Off mode.

Activate the self-test mode by pressing and holding the On/Off POWER button while turning on the AC power. Be sure to continue to hold the **POWER** button until the power on reset is completed. The controller is now in the **Self-Test** mode.

Once activated the self-test software will continuously execute the following procedure:

- 1 - Turn on in the **HEAT** mode and supply heating for ten (10) minutes.
- 2 - Stop heating and run the **fan only** for five (5) minutes.
- 3 - Switch to **COOL** and continue cooling for ten (10) minutes.
- 4 - Stop cooling and run the **fan only** for five (5) minutes.
- 5 - Return to step one (1) and continue until interrupted.

The test mode will continue until the power is interrupted or the test is halted by pressing the On/Off POWER button once.

Service Tools

Hour Meter

Total compressor cycle time is saved in **EEPROM** every 6 minutes of continuous compressor running time. Cycles less than 6 minutes will be discarded to conserve memory and to allow for the most flexible hour-meter possible.

To view the hour meter turn off the power at the AC breaker and hold the **DOWN** arrow button depressed. While depressing the **DOWN** arrow button, restore AC power. After the power on reset routine is complete, the following will appear on the display.

HOUR METER			THOUSANDS			HOURS		
H	r				1	2	2	4

1. The hour meter mnemonic (Hr) is displayed for one (1) second.

Marvair® Reverse Cycle Air Conditioners

2. The display blanks out for one second and then displays the THOUSANDS units for three (3) seconds.
3. The display blanks out for one (1) second and then displays the hours for three (3) seconds.
4. The unit returns to the last operating state before power was removed.

The example shown is displaying twelve-hundred twenty-four (1,124) hours.

Maximum recorded time is 10,000 hours. The hour meter stops at the maximum (10,000 hrs) and can only be reset by **Marvair**.

Service History

The controller will record and remember the last eight (8) service problems or service faults detected. Each time a fault is detected, a one hour timer is started. During that hour the same recurring fault will not be recorded. Should a different fault be detected during that hour, it will be entered into the service history log.

The following events are entered into the service history log:

1. High Refrigerant Pressure
2. Low Refrigerant Pressure
3. Air Sensor Fault
4. Low AC Voltage
5. Pump or Loss of Water Fault

To view the service log, turn off the AC power and depress the **MODE** button. With the **MODE** button depressed turn on the AC power. Once the **power on reset** is completed, the display will flash the most recent mnemonic for the fault detected, followed by the event number. To view the other events detected press either the **UP** or **DOWN** arrow buttons.

To exit the service history log press the **POWER** or the **MODE** button or wait 30 seconds without pressing any buttons.

The service log can be cleared by simultaneously pressing the **POWER** and **DOWN** arrow buttons while you are viewing the service log mode.

Double check all electrical connections and all hose connections.

Cooling Cycle

1. Turn the seacock valve to the open position.
2. On SPB models, there is a short delay on starting. On SPM models, set the delay to 15 seconds. If there is more than one unit, set the delays to different times.
3. If the water pump has a dedicated breaker, turn it on. Verify that water is being discharged overboard.

Marvair® Reverse Cycle Air Conditioners

4. Turn on the circuit breaker to the Marvair® unit.
5. Refer to the operating instructions in this manual for the MachAir controller or the thermostat & set the system for cooling by using the display module or the thermostat.
6. Adjust the cooling temperature set point on the display module or the thermostat higher than the cabin temperature.
7. Slowly lower the thermostat's cooling set point until the set point is below the cabin temperature. The blower, compressor and pump should be operating.
8. Close all doors and hatches.
9. Allow the unit to operate 10 minutes.
10. After 10 minutes, there should be a 15°F (8°C) to 20°F (9°C) difference in the supply and return air temperatures.

Heating Cycle

Note: Do not turn unit “OFF” and then immediately back “ON”. Wait three minutes to allow refrigerant pressures to equalize.

1. Follow steps 1, 2 & 3 as outlined above in the Cooling Cycle section.
2. Refer to the operating instructions in the manual & set the system for heating by using the display module or the thermostat.
3. Adjust the heating temperature set point on the display module or the thermostat higher than the cabin's temperature.
4. Slowly raise the thermostat's heating set point until the set point is above the cabin temperature. The blower, compressor and pump should be operating.
5. Close all doors and hatches.
6. Allow the unit to operate 5 minutes.
7. After 5 minutes there should be a 15°F (8°C) to 25°F (9°C) difference in the supply and return air temperature.

Operation Checklist

1. Verify that all tie downs clamps have been correctly installed
2. Make sure all electrical cover plates are in place
3. Test for continuity between the ground and the boat's bonding system or the engine's DC negative connection
4. Make sure that there are zero volts between the boat's ground and the ground in the SeaMach reverse cycle air conditioner with the unit operating.
5. Check all water hoses for leaks.
6. Make certain that poisonous gases or noxious fumes are NOT being introduced into the vessel via the HVAC system.
7. Check for proper condensate drainage.

Marvair® Reverse Cycle Air Conditioners

Chapter 5 - Winterizing the System

There are two scenarios for winterizing the system – the boat remains in the water or the boat is out of the water, in dry dock storage. Please follow the procedures described below for your situation.

Boat remains in the water

In water storage requires the use of a potable anti-freeze solution throughout the system's water supply and discharge lines. Be sure to follow all state, local and federal ordinances before discharging an anti-freeze solution overboard.

1. Close ball valve.
2. Disconnect water line at ball valve.
3. Insert line into a bucket of potable anti-freeze.
4. Run air conditioner until a solid stream of anti-freeze is being discharged overboard.
5. Reconnect water line at ball valve.

Boat is out of water in dry dock

With the boat out of the water:

1. Open the seacock to permit all the water to drain out of system via the thru-hull fitting.
2. Remove and empty the seawater strainer basin.
3. Loosen the screws on the pump head to allow the water to drain from the pump and from the water line between the pump and strainer.
4. Close the seacock.

When the boat is put back into the water in the spring:

1. Gradually open the seacock to allow water to fill the system to the level of the pump.
2. Tighten the pump face to achieve a seal.
3. When pump is primed, open the seacock valve completely.

Marvair® Reverse Cycle Air Conditioners

Chapter 6 – Troubleshooting



WARNING

Troubleshooting and repair of the Marvair® unit should only be performed by qualified personnel.

Troubleshooting Guide

PROBLEM/SYMPTOM	LIKELY CAUSE(S)	CORRECTION
The unit does not operate. (nothing works a all)	1. Power supply problem.	1. Check voltage at power supply and at the electrical box. Check wiring to unit and at shore, boat and unit (if applicable) breakers or fuses. Check shore power connection.
	2. Tripped breaker/disconnect.	2. Check circuit protection devices for continuity.
	3. Display/Controller.	3. Setpoint may be too high if in cooling mode or too low if in heating mode; check unit and reset. Display/Controller may be out of calibration or otherwise defective. Also check for loose connection(s).
	4. Low Voltage.	4. Check voltage at dock. Check panel voltage. Check shore connections and shore cord. Check voltage at board in the unit. If low, check wiring connections.
Unit has power, but display/controller is inactive.	1. Check interface cable connections. Control is faulty.	1. Replace
Blower runs but compressor does not start.	1. Power supply problem.	1. Check voltage at power supply. Voltage at unit must be within 10% of rated nameplate voltage.
	2. Display/Controller.	2. Check the display/controller and unit for loose wires. Secure any loose connection. Fan is programmed to run with the compressor. Adjust set points or reset defaults. Check location of sensor and make sure that it does not touch the indoor coil. The sensor and/or thermostat should be replaced if defective.
	3. Safety switches are tripping out unit.	3. Check for water flow. Check for proper air flow. Check refrigerant charge. Check switches for loose wire connection, broken or burned contacts.
	4. Loose or defective wires.	4. Tug on wires to see if they will separate from their connections. Replace terminals if they are loose or weak.

Marvair® Reverse Cycle Air Conditioners

PROBLEM/SYMPTOM	LIKELY CAUSE(S)	CORRECTION
Blower runs but compressor does not start. <i>(continued)</i>	5. Compressor. 6. Refrigerant leakage or loss. 7. Control board. 8. Compressor Run Capacitor.	5. Check for power to compressor on PC board. Check for electrical shorts, ground and open circuits. Check for electrical shorts, ground and open circuits. Replace compressor if defective. If electrical checks are ok, install a start capacitor and direct wire to see if the compressor will start. If this fails, remove and replace the compressor. 6. Locate leak(s), reclaim, repair, evacuate and recharge unit with refrigerant. 7. Verify that power is being provided from the control board. Replace control board if it is defective. 8. Verify capacitance, check for electrical shorts and ground. If defective, replace.
Compressor runs, but blower will not run.	1. Blower motor capacitor. 2. Blower motor. 3. Power supply problem. 4. Control board.	1. Verify capacitance, check for electrical shorts and ground. If defective, replace. 2. Check for electrical shorts, ground and open circuits. Replace blower motor if it is defective. 3. Check voltage at power supply. Voltage at unit must be within 10% of rated nameplate voltage. 4. Verify that power is being provided from the control board. Replace control board if it is defective.
Display/controller calling for heating and unit is in cooling mode.	1. No power to reversing valve or bad valve.	1. Check wiring to valve. Replace valve if defective.
Unit trips off on high pressure in cooling mode or low pressure in the heating mode, but pump is running.	1. Low water flow to the condenser. 2. Pump is air locked.	1. Check water lines to the unit for kinks in line. Check strainer and thru hull for obstructions. Clean as required. Verify seacock (ball valve) is open. Check for obstruction in the pump and remove. 2. Purge air from system
Pump does not run.	1. Compressor is off and the pump is programmed to run with the compressor. 2. If there is a pump relay, check pump circuit breaker. 3. No power to pump at control board. 4. Faulty pump. ¹	1. Adjust set point. 2. Reset breaker. 3. Control board may be faulty. 4. Replace pump.

Marvair® Reverse Cycle Air Conditioners

Low air flow.	<ol style="list-style-type: none"> 1. Dirty filter. 2. Return air flow blocked. 3. Louvers in grille closed. 4. Fan speed set too low. 	<ol style="list-style-type: none"> 1. Clean filter. 2. Remove obstruction. 3. Open louvers. 4. Raise fan speed and reset program parameters.
Low Water Flow ¹	<ol style="list-style-type: none"> 1. Restriction or blockage in waterline. 2. Air lock in pump 	<ol style="list-style-type: none"> 1. Clean raw water strainer. Clean thru hull. Make sure valve is open. Clean pump. 2. Open ball valve, remove discharge hose and open valve to bleed air from the pump. Check pump's impellor for wear or debris.
Unit provides insufficient cooling.	<ol style="list-style-type: none"> 1. Restriction in water system. 2. Water pump. 3. Air filter. 4. Indoor coil. 5. Ice on indoor coil. 6. Unit is undersized 7. Low refrigerant 	<ol style="list-style-type: none"> 1. Strainer or thru-hull fitting are clogged. Clean and check for water flow. Make sure seacock (ball valve) is open. 2. Check for electrical shorts, ground and open circuits. Replace water pump if it is defective. Replace water pump if it is undersized. 3. Clean or replace the air filter if it is dirty. 4. The indoor coil may require cleaning if the unit was operated without a filter. 5. Thermostat setting is too low. Shut down unit until ice has melted and restart at a higher temperature setting. Check to see if filter is dirty or long or restricted ductwork. 6. Check if the unit is undersized for the load. Replace with larger unit or add additional unit(s) if necessary. 7. Add refrigerant
Unit provides insufficient heating.	<ol style="list-style-type: none"> 1. Restriction in water system. 2. Water pump. 3. Air filter. 4. Indoor coil. 5. Unit is undersized. 6. Water temperature. 	<ol style="list-style-type: none"> 1. Strainer or thru-hull fitting are clogged. Clean and check for water flow. Make sure seacock (ball valve) is open. 2. Check for electrical shorts, ground and open circuits. Replace water pump if it is defective or undersized. 3. Clean or replace the air filter if it is dirty. 4. The indoor coil may require cleaning if the unit was operated without a filter. 5. Check if the unit is undersized for the load. Replace with larger unit or add additional unit(s) if necessary. 6. Check water inlet temperature using a thermometer. Low inlet water temperatures, less than 50°F (10°C), combined with high heating set points and restricted air flow can cause low pressure trips. Check heating set point and air flow.

Marvair® Reverse Cycle Air Conditioners

PROBLEM/SYMPTOM	LIKELY CAUSE(S)	CORRECTION
Unit provides insufficient heating. <i>(continued)</i>	7. Reversing valve.	7. Check for power to the solenoid coil, verify that the coil is functional. If the unit still does not switch to heating, replace the reversing valve, evacuate and recharge the unit.
	8. Low refrigerant	8. Add refrigerant
Noise operation.	1. Copper tubing is vibrating.	1. Adjust by bending slightly to a more stable position. Separate any tubing that is making contact with other tubing or components.
	2. Indoor blower assembly.	2. If blower wheel is hitting housing, adjust the wheel position in the housing. Replace blower motor or assembly if the bearing(s) are defective.
	3. Loose cabinet or components.	3. Check and tighten loose screws.
	4. Improper unit installation.	4. Make sure unit is level and secure to deck.
Water is leaking from unit.	1. Condensate pan.	1. Check for leaks and repair as required.
	2. Condensate drain line or pump.	2. Check for leaks and repair as required.
	3. Loose fittings or connections.	3. Tighten fittings and connections. Check the condensate drain line for leaks.
Electrical shock at unit.	1. Electrical component is shorted to ground.	1. Check control board, blower motor, compressor and pumps with an ohmmeter or high potential tester. Determine what is grounded and replace or rewire.
		2. Line trip is too sensitive

¹Cal pumps are built with an auto-reset thermal breaker to minimize the chance for motor burn out. If water flow is too low, the pump will turn off until it cools down. Do not assume that the pump is defective. Check the pump by feeling the pump housing to determine if it is on or turned off due to the protective thermal shut down. If the pump is running or very hot – more than 40°F higher than the surrounding air temperature- investigate the other reasons for low water flow. If the pump is not running and cool to the touch, check for power to the pump.

Marvair® Reverse Cycle Air Conditioners

Alarm Screens

A complete description of the alarm screens can be found in the section that describes the display/controller for your Marvair Marine unit. A high pressure alarm when in the cooling mode or a low pressure alarm in the heating mode is typically caused by a lack of water flow. A low pressure alarm when the unit is in the cooling mode or a high pressure alarm when the unit is in the heating mode typically means that there is insufficient air flow. Refer to the Troubleshooting table for diagnosing and correcting these problems.

Fault	Mode of Operation	Likely Cause
High Pressure Alarm	Cooling	Low Water Flow
Low Pressure Alarm	Cooling	Inadequate Air Flow
High Pressure Alarm	Heating	Inadequate Air Flow
Low Pressure Alarm	Heating	Low Water Flow

Chapter 7 – Warranty

Marvair® Marine Self-Contained and Split Systems Warranty

Parts

If any part of your Marvair® unit fails because of a manufacturing defect within twenty-four months from the date of purchase of a new boat or within twenty-four months from the date of installation of the air conditioner, but not to exceed thirty-six from the date of manufacture by Marvair, Marvair will furnish without charge, EXW Cordele, Georgia, the required replacement part.

Labor

If any part of your Marvair® reverse cycle air conditioner fails because of a manufacturing defect within twenty-four months from the date of purchase of a new boat or within twenty-four months from the date of installation of the air conditioner, but not to exceed thirty-six from the date of manufacture by Marvair, Marvair will pay for the related service labor to replace the failed part according to the Marvair Flat Rate Schedule currently in effect. The owner must provide proof of the date of the purchase of the boat or date of installation of the Marvair® unit. The owner's registration card filed with Marvair, the invoice for the purchase of the vessel, an invoice for the installation of the Marvair® unit, or similar documents are examples of proof of the date.

When service is required, it must be performed during normal working hours (8:00 a.m. to 5:00 p.m.) Monday through Friday and must be performed by Marvair personnel or their designated Service Representative.

The responsibility of the Owner of the Equipment includes the following:

1. To operate the equipment according to the manufacturer's instructions.
2. To provide easy accessibility for service.
3. To check and reset circuit breaker(s) and disconnect before calling for service. (Circuit breaker(s) may be in the main service panel.)
4. To keep the unit clean and free of dirt.

Marvair® Reverse Cycle Air Conditioners

5. To clean and/or replace the filter as required. (The filter may be located in the return air filter grille or in front of the evaporator coil.)
6. To keep the evaporator coil clean and the condenser coil free of sediment or scale.
7. To pay the charges incurred when any of the above have not been done.
8. To pay for repair or replacement of any material or part other than those within the Marvair unit or thermostat itself.
9. To check any fuses on the circuit board and replace as required.

The owner of the product may ship the allegedly defective or malfunctioning product or part to Marvair, at such owner's expense, and Marvair will diagnose the defect and, if the defect is covered under this warranty, Marvair will honor its warranty and furnish the required replacement part. All costs for shipment and risk of loss during shipment of the product or part to Marvair and back to the owner shall be the responsibility and liability of the owner. Upon request by an owner, Marvair may arrange for remote diagnosis and repair of the allegedly defective or malfunctioning product or part.

An owner requesting performance under this Warranty shall provide reasonable access to the allegedly defective or malfunctioning product to Marvair and its authorized agents and employees.

This warranty does not cover damage caused by improper installation including any refrigerant leaks in the tubing and fittings between the evaporator and condenser sections on split systems; misuse of equipment; negligent servicing; damage due to use of the product for purposes other than those for which it was designed; damage caused by natural disasters, power surges, lightning and submersion; damage caused by unauthorized modifications; and damage caused by improper wiring or power supply to the air conditioner including operating the unit with an undersized generator.

THIS WARRANTY AND SERVICE POLICY CONSTITUTE THE EXCLUSIVE REMEDY OF ANY PURCHASER OF A MARVAIR REVERSE CYCLE AIR CONDITIONER AND IS IN LIEU OF ALL OTHER WARRANTIES, EXPRESSED OR IMPLIED, INCLUDING, WITHOUT LIMITATION, ANY IMPLIED WARRANTY OF MERCHANTABILITY OR FITNESS FOR USE, TO THE FULLEST EXTENT PERMITTED BY LAW. IN NO EVENT SHALL ANY IMPLIED WARRANTY OF MERCHANTABILITY OR FITNESS FOR USE EXCEED THE TERMS OF THE APPLICABLE WARRANTY STATED ABOVE AND MARVAIR SHALL HAVE NO OTHER OBLIGATION OR LIABILITY. IN NO EVENT SHALL MARVAIR BE LIABLE FOR INCIDENTAL OR CONSEQUENTIAL DAMAGES OR MONETARY DAMAGES.

THIS WARRANTY GIVES YOU SPECIFIC LEGAL RIGHTS, AND YOU MAY ALSO HAVE OTHER RIGHTS WHICH VARY FROM STATE-TO-STATE. Some states do not allow limitations or exclusions, so the above limitations and exclusions may not apply to you.

8/07 Rev. 4