

↗ DOMETIC

MARINE

CONTROL UNITS

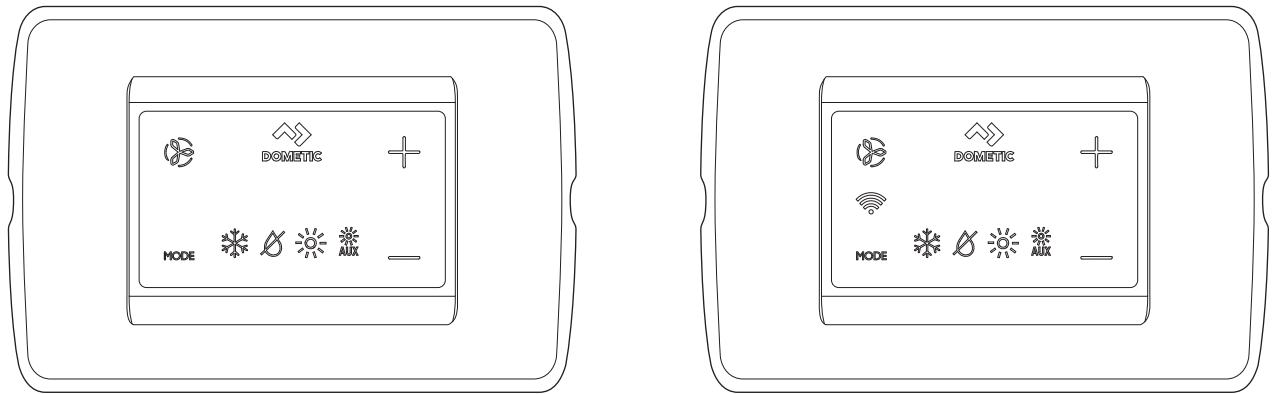

CapTouch and CapTouch Wi-Fi

EN	CapTouch Cabin Control
	Installation and Operating Manual 2

⚠ WARNING
Cancer and Reproductive Harm www.P65Warnings.ca.gov

Service Center & Dealer Locations

Visit: www.dometic.com

Read these instructions carefully. These instructions **MUST** stay with this product.

Contents

1 Explanation of Symbols and Safety Instructions 2

1.1 Recognize Safety Information 2

1.2 Understand Signal Words 2

1.3 Supplemental Directives 3

1.4 General Safety Messages 3

2 Intended Use 3

3 General Information 3

3.1 Tools and Materials 3

3.2 Display Features 4

4 Specifications 4

4.1 Product Dimensions 4

4.2 Cable Length 5

4.3 Available System Inputs 5

4.4 Operational Specifications 5

5 Wiring Diagrams 6

6 Installation 8

6.1 Choosing a Display Panel Location 8

6.2 Preparing the Wall 8

6.3 Installing an Optional Sensor 8

6.4 Mounting the Display Panel 9

6.5 Testing the Display 9

7 Operation 9

7.1 Understanding the Heating and Cooling Cycles 10

7.2 Choosing the Control Operation 11

7.3 Using the Control Display Panel 13

7.4 Programming the Control 14

7.5 Using the CapTouch Wi-Fi Application 21

7.6 Registering a Thermostat 29

7.7 Managing An Active CapTouch Subscription 31

7.8 Navigation Tree 34

8 Troubleshooting 35

9 Disposal 39

10 Warranty Information 39

1 Explanation of Symbols and Safety Instructions

This manual has safety information and instructions to help you eliminate or reduce the risk of accidents and injuries.

1.1 Recognize Safety Information

 **This is the safety alert symbol.** It is used to alert you to potential physical injury hazards. Obey all safety messages that follow this symbol to avoid possible injury or death.

1.2 Understand Signal Words

A signal word will identify safety messages and property damage messages, and also will indicate the degree or level of hazard seriousness.

 **DANGER!**
Indicates a hazardous situation that, if **not** avoided, will result in death or serious injury.

 **WARNING**
Indicates a hazardous situation that, if **not** avoided, could result in death or serious injury.

 **CAUTION**
Indicates a hazardous situation that, if **not** avoided, could result in minor or moderate injury.

NOTICE: Used to address practices **not** related to physical injury.

 Indicates additional information that is **not** related to physical injury.

1.3 Supplemental Directives

To reduce the risk of accidents and injuries, please observe the following directives before proceeding to install or operate this appliance:

- Read and follow all safety information and instructions.
- Read and understand these instructions before installing and operating this product.
- The installation must comply with all applicable local or national codes, including the latest edition of the following standards:
 - ANSI/NFPA70, National Electrical Code (NEC)
 - American Boat and Yacht Council (ABYC)

1.4 General Safety Messages

⚠ WARNING: ELECTRICAL SHOCK, FIRE, AND/OR EXPLOSION HAZARD. Failure to obey the following warnings could result in death or serious injury:

- Use only Dometic replacement parts and components that are specifically approved for use with the appliance.
- Avoid improper installation, adjustment, alteration, service, or maintenance of the appliance. Service and maintenance must be done by a qualified service person only.
- Do **not** modify this product in any way. Modification can be extremely hazardous.
- This product should be installed in a controlled, indoor environment.

2 Intended Use

The CapTouch control is a user-friendly capacitance touchscreen display for basic thermostat operation. The micro controller-based unit is designed for use with direct expansion (DX), reverse-cycle air-conditioning systems, and chilled-water systems (CW). The display panel has 34 programmable parameters, automatic and manual fan speeds, standard and optional sensor inputs, and fits both Vimar® Idea and Eikon switch bezels.

This manual provides all necessary information for the proper installation and operation of the CapTouch display panel. Poor installation and misunderstood operating parameters will result in unsatisfactory performance and possible failure. The manufacturer accepts no liability for damage in the following cases:

- Faulty assembly or connection
- Damage to the product resulting from mechanical influences and excess voltage
- Alterations to the product without express permission from the manufacturer
- Use for purposes other than those described in the operating manual

Dometic Corporation reserves the right to modify appearances and specifications without notice.

3 General Information

This section provides information on the tooling, parts, and display features for the CapTouch control.

i The images used in this document are for reference purposes only. Components and component locations may vary according to specific product models. Measurements may vary ± 0.38 in. (10 mm).

The CapTouch control models have the same features, installation procedure, and functionality, except for the Wi-Fi capability. Refer to "Using the CapTouch Wi-Fi Application" on page 21 for details on the full functionality of the Wi-Fi capability.

3.1 Tools and Materials

Dometic recommends that the following tools and materials be used while installing the appliance:

Recommended Tools	
Phillips-head Screwdriver	Saw
Safety Glasses	

Included Parts	Quantity
Screws	4
CapTouch Control or CapTouch Wi-Fi Control	1

Additional Parts ¹	DX	CW
Required for CW Installations (not included)		
Water Inlet Temperature Sensor		X
Optional Parts		
Outside Air Temperature (OAT) Sensor	X	X
Inside Air Temperature Sensor	X	X
Auxiliary Electric Heater	X	X
Room Temperature/Relative Humidity Combination Sensor	X	X
Seawater Low-Limit Temperature Sensor	X	
Pump Sentry Water Sensor	X	

¹ Additional parts are not included with the standard control package.

i The maximum length for the display and sensor cables is 75 ft (22.9 m).

3.2 Display Features

This section explains the function of the icons on the CapTouch and CapTouch Wi-Fi displays.

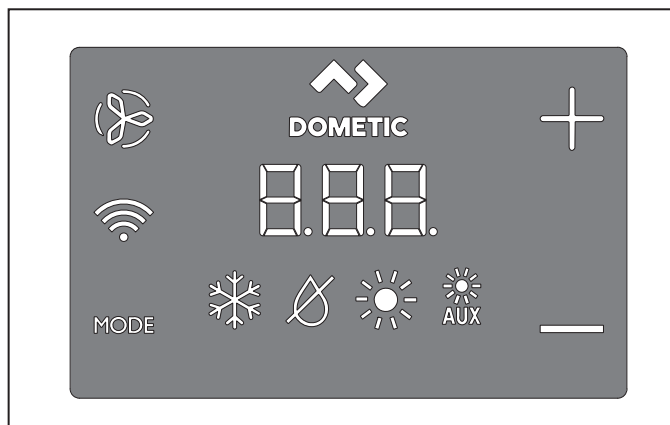

1 CapTouch Wi-Fi Control Display

Icon	Name	Function
	Fan	Cycles through the different fan speeds
	Dometic	Brand identification. No operational function
	Up	Raises the temperature set point
	Down	Lowers the temperature set point

Icon	Name	Function
	Temperature Indicator	Displays the inside, set point, outside, and water temperatures, as selected
	Mode Indicator	Indicates the current display mode
	HVAC Mode	<ul style="list-style-type: none"> • Cycles through the different modes • Sends the display to sleep if held for three seconds
	Wi-Fi Indicator	<ul style="list-style-type: none"> • Applicable to CapTouch Wi-Fi model only • Indicates Wi-Fi is active if lit.

4 Specifications

The following table lists the CapTouch control dimensions, cable lengths, system inputs, and operational specifications.

4.1 Product Dimensions

Display Panel Dimensions for the Idea Bezel	4.4 in. x 3.0 in. (112 mm x 76 mm)
Display Panel Dimensions for the Eikon Bezel	4.5 in. x 2.9 in. (114 mm x 74 mm)
Cut-Out Dimensions for the Idea Bezel	2.3 in. x 3.5 in. (58 mm x 89 mm)
Cut-Out Dimensions for the Eikon Bezel	1.9 in. x 2.8 in. (48 mm x 71 mm)

4.2 Cable Length

Display Cable Self-Contained	15.0 ft (4.6 m) Standard
Inside Air Temperature Sensor (optional)	7.0 ft (2.1 m) Standard
OAT Sensor (optional)	15.0 ft (4.6 m) Standard
All custom cable lengths are supplied in standard 5 ft (1.5 m) increments	75.0 ft (22.9 m) Maximum

4.3 Available System Inputs

Water Inlet Temperature Sensor (CW Installations Only)	1
High Refrigerant Pressure	1
Inside Air Temperature Sensor (optional)	1
Low Refrigerant Pressure (optional)	1
OAT Sensor (optional)	1
Pump Sentry Water Sensor (optional) (DX Installations Only)	1
Room Temperature/Relative Humidity Combination Sensor (optional)	1

4.4 Operational Specifications

Set Point Operating Range	55 °F to 99 °F (13 °C to 37 °C)
Ambient Temperature Operating Range Displayed	5 °F to 150 °F (-15 °C to 66 °C)
Sensor Accuracy	± 2 °F @ 77 °F (±1 °C @ 25 °C)
Low Voltage Limit 100–120 V	95 VAC
Low Voltage Limit 200–240 V	195 VAC
Low Voltage Processor Reset	50 VAC
Universal Line Voltage	100–240 VAC
Frequency	50 Hz or 60 Hz
Fan Output	6 A @ 115 VAC
	6 A @ 230 VAC
Valve Output	5 A @ 115/230 VAC
For CW Only: Auxiliary Electric Heater Output (using compressor output L1 and L2)	30 A Maximum
External Triac	26 A
External Q-Relay	30 A Maximum
Pump Output	1/4 HP @ 115 VAC
	1/2 HP @ 230 VAC
Compressor Output	1 HP @ 115 VAC
	2 HP @ 230 VAC
Minimum Operating Temperature	0 °F (-18 °C)
Maximum Ambient Operating Temperature	180 °F (82 °C)
Maximum Rh Conditions	99% Non-condensing
Power Consumption	< 5 W

5 Wiring Diagrams

⚠ WARNING: ELECTRIC SHOCK HAZARD.

Turn power OFF before performing any electrical installation or maintenance activities. Failure to obey this warning could result in death or serious injury.

Figure 2 and Figure 3 provide examples of the DX and CW Wiring for the CapTouch controls.

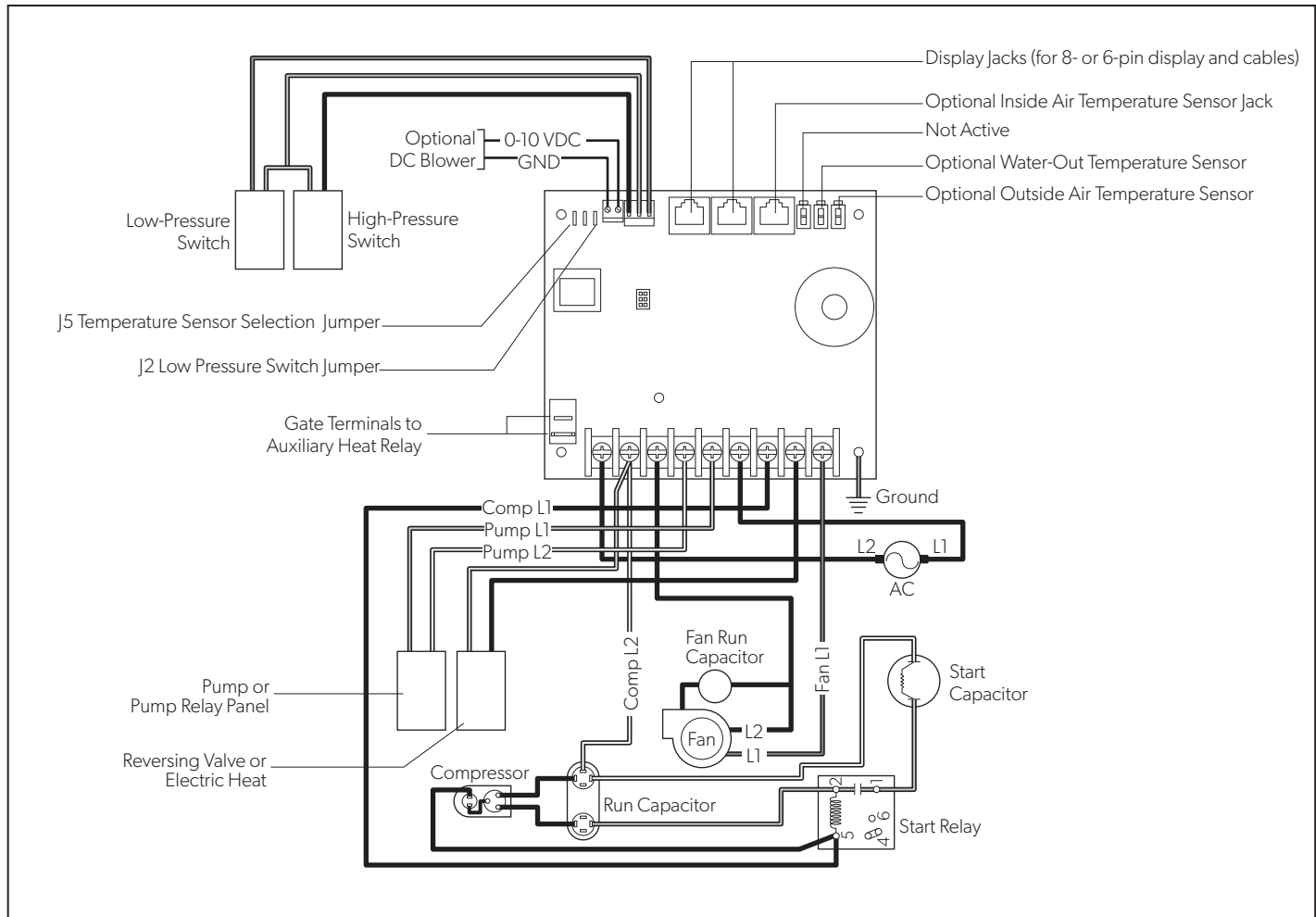

2 DX Wiring Diagram

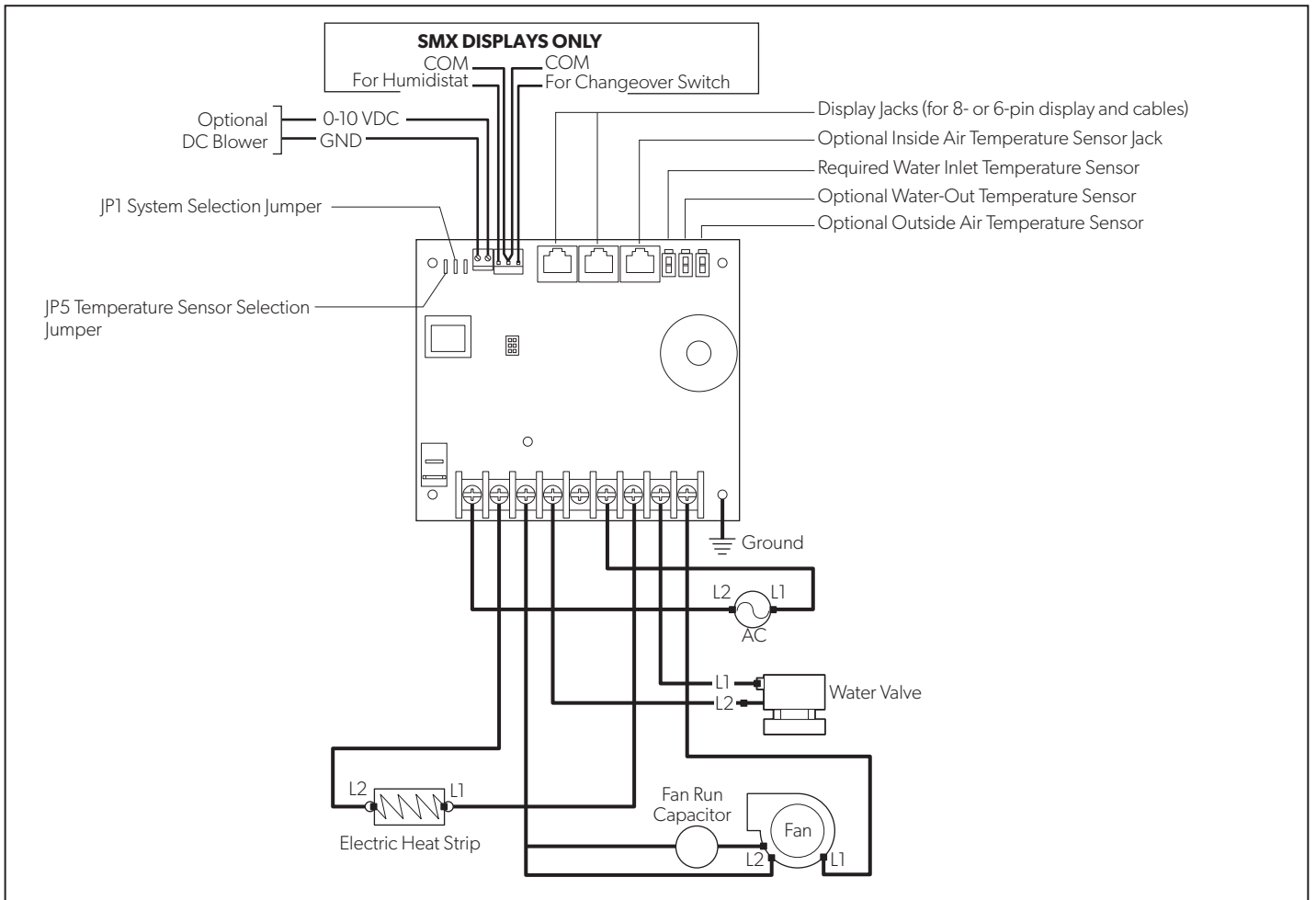

3 CW Wiring Diagram

6 Installation

⚠ WARNING: ELECTRIC SHOCK HAZARD.

Turn power OFF before performing any electrical installation or maintenance activities. Failure to obey this warning could result in death or serious injury.

NOTICE: Failure to obey the following notices could result in damage to the product:

- Do **not** locate the display panel in direct sunlight, near any heat-producing appliances, or in a bulkhead where temperatures radiating from behind the panel may affect performance.
- Do **not** mount the display in the supply-air stream or above or below a supply-air or return-air grille.
- Do **not** mount the display behind a door, in a corner, under a stairwell, or any place where there is no freely circulating air.
- Do **not** staple sensor cables during installation.
- Do **not** use a screw gun and do **not** overtighten the screws when mounting the display. Either method may damage the display.

i The display built-in temperature sensor is located in the control's display panel. An optional inside air temperature sensor is required if installing the display panel in a cabinet, enclosed space, or any area where the accurate sensing of the room temperature would be impaired.

This section describes how to install a CapTouch control.

6.1 Choosing a Display Panel Location

Place the display panel in an area that meets the following location criteria:

- Mounted on an inside wall of the cabin, away from direct sunlight
- Sets slightly higher than mid-height of the cabin
- Located in an area of freely circulating air
- Placed a maximum distance of 15 ft (4.6 m) from the air conditioner

6.2 Preparing the Wall

Cut the cabin wall to fit the display panel, according to the bezel being used.

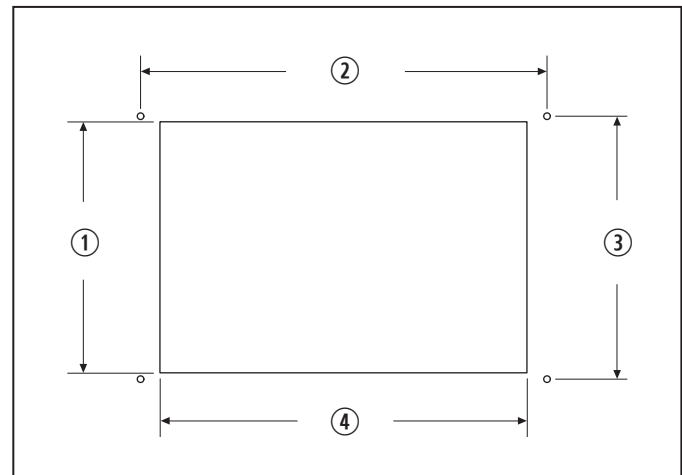

4 Idea Bezel Cutout Dimensions

- | | |
|-------------------|-------------------|
| ① 2.3 in. (58 mm) | ③ 2.4 in. (61 mm) |
| ② 3.8 in. (97 mm) | ④ 3.5 in. (89 mm) |

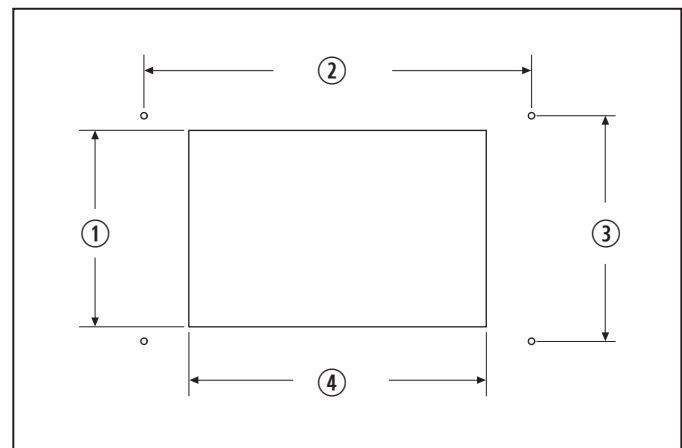

5 Eikon Bezel Cutout Dimensions

- | | |
|-------------------|-------------------|
| ① 1.9 in. (48 mm) | ③ 2.2 in. (56 mm) |
| ② 3.8 in. (97 mm) | ④ 2.8 in. (71 mm) |

6.3 Installing an Optional Sensor

1. Mount the optional sensor according to the installation instructions included with the sensor.
2. Plug the sensor cable into the appropriate sensor jack on the upper side of the control board. Refer to "Wiring Diagrams" on page 6 for details on the sensor jack locations.

6.4 Mounting the Display Panel

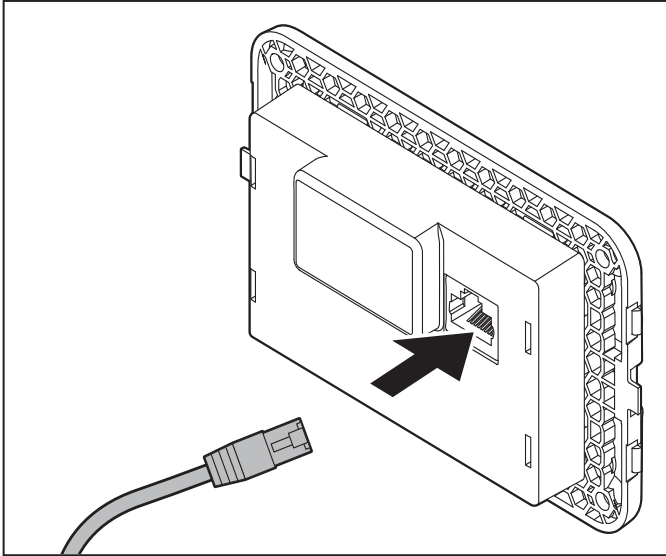

6 Plugging in the Display Cable

1. Plug the display cable 8-pin connector into the upper-right jack on the circuit board.
2. Insert the other end of the display cable into the display jack on the back of the display panel.

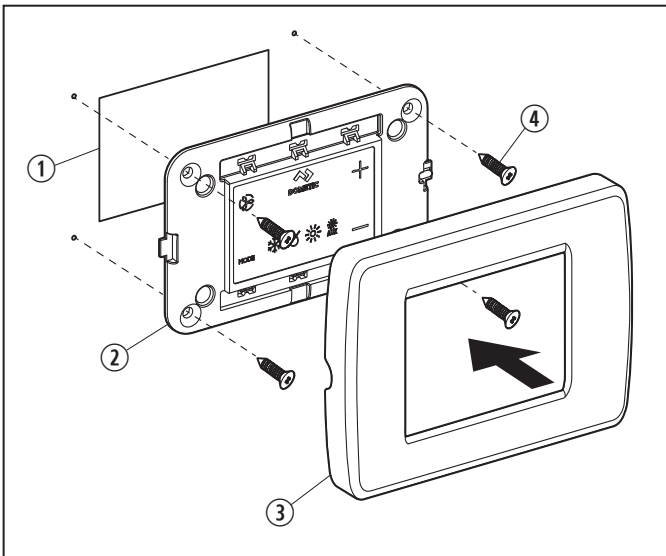

7 Securing the Display

- | | |
|-----------------|---------|
| ① Cutout | ③ Bezel |
| ② Display Panel | ④ Screw |

3. Use the four screws provided to secure the display panel to the bulkhead. Do not use a screw gun or overtighten the screws.
4. Snap the bezel onto the display panel frame.

6.5 Testing the Display

NOTICE: For DX units only: do **not** turn the circuit breaker or power supplied to the unit OFF and then immediately turn it back ON. Allow at least five minutes for the refrigerant pressure to equalize. Failure to obey this notice could result in damage to the product.

1. Open the seawater-intake ball valve (seacock).
2. Turn the display OFF. Wait a minimum of five minutes.
3. Turn the air conditioner circuit breaker ON.
 - ⓘ If the seawater pump is on a separate circuit breaker, be sure to turn it ON.
4. Turn the display ON.
5. Tap the **Fan** icon.
6. Verify that the fan is running and that a steady airflow is coming out of the supply-air grille.
7. Select a temperature set point lower than the current cabin temperature.
8. Verify that a steady, solid stream of water is coming out from the overboard discharge.
9. Verify that a steady airflow continues to flow out of the supply-air grille.
 - ⓘ If the unit is not functioning as expected, refer to "Troubleshooting" on page 35.

7 Operation

NOTICE: If the unit is cool-only, change parameter P-13 to CL, then select AUTOMATIC mode. Do **not** set the unit to AUTOMATIC mode before changing parameter P-13 to CL. Cool-only units do **not** heat unless equipped with auxiliary heating. Failure to obey this notice will cause the unit to cool in both modes. Refer to "Selecting a Parameter" on page 15.

- ⓘ When used with an optional auxiliary electric heater, the fan remains ON for four minutes after the heater cycles OFF, even if the fan is set to cycled operation.
- ⓘ The images in this section show the CapTouch control display, unless otherwise indicated.

This section describes the cycle, programming, and functions for the CapTouch controls.

7.1 Understanding the Heating and Cooling Cycles

The heating and cooling cycles operate differently depending on the system installed. This section describes the possible cycles.

7.1.1 Normal Heating or Cooling Cycle

In AUTOMATIC mode, heating and cooling are supplied as required to meet the cabin temperature set point.

- The system starts a cooling cycle once the cabin temperature exceeds the temperature set point by 2 °F (1 °C) and starts a heating cycle once the cabin temperature falls below the temperature set point by 2 °F (1 °C). The system continues the cycle until the cabin temperature equals the set point.
- During a cycle, the cabin temperature must drop below the set point by at least 4 °F (2 °C) before the system switches from cooling to heating or exceed the set point by at least 4 °F (2 °C) before the system switches from heating to cooling. This behavior prevents small temperature overshoots from causing the system to switch between heating and cooling when it is not necessary.

COOL mode supplies cooling only and HEAT mode supplies heating only.

- The cabin temperature for either mode is maintained within 2 °F (1 °C) of the set point by default.
- When the heating or cooling set point is satisfied, the compressor cycles OFF and the fan returns to low speed.

In Manual Fan Mode, the fan speed remains constant.

7.1.2 Chilled-Water System Operation (CW Systems Only)

In CW systems, the water valve does not open unless the water temperature is adequate to heat or cool the cabin. The adequate heating or cooling water temperature is defined by the water temperature differential setting in the control parameters. Refer to “Selecting a Parameter” on page 15.

To view the current water temperature, tap and hold **Fan** and **Up** simultaneously for three seconds. Refer to “Using the Control Display Panel” on page 13. The fan remains on low speed until the adequate water temperature is available.

- i** To provide heat when the required water temperature is not available, install the optional auxiliary electric heater, and program parameter P-28. Refer to “Programming the Control” on page 14.

7.1.3 Reversing-Valve Operation (DX Systems Only)

COOL mode or HEAT mode is determined by the position of the reversing valve. The reversing valve is programmed to automatically toggle in these situations:

- When the system is running and an opposite cycle is needed to maintain the temperature, the reversing valve will toggle to the opposite position to initiate the opposite cycle and reduce the starting surge of the compressor.
- When a cooling or heating cycle is initiated after the system has been OFF for less than five minutes.
- When a cycle is interrupted by changing the display mode to OFF or changing the set point from the display panel.

To reduce reversing-valve noise, unnecessary valve toggling is limited by default. Program the minimum compressor staging delay (parameter P-3) to five minutes or greater, to eliminate valve toggling. Refer to “Programming the Control” on page 14.

- i** When the system is powered up, a power-on-reset always initiates a valve toggle.

7.1.4 De-icing Cycle (DX Systems Only)

DX systems have a de-icing cycle option to prevent ice buildup on the evaporator coil during extended periods of cooling operation. Installation variables, such as grille sizes, length of ducting, insulation, and ambient temperatures, determine the runtime required to achieve the set point.

Factors that substantially increase the runtime include operating the system with hatches and doors open and programming an unrealistic set point (e.g. 65 °F/18 °C). Such situations can cause the evaporator to form ice on warm humid days.

De-icing is accomplished by closely monitoring the room air temperature in 10-minute intervals during a cooling cycle. Depending on the parameter value and the change in room temperature during these monitoring intervals, the control performs various actions to prevent ice from forming or to melt ice that has already formed. This is accomplished by short compressor shutdown periods combined with a one-speed increase in the fan speed, and by periodic HEAT mode cycles with the fan turned off.

The de-icing cycle algorithm initiates periodic compressor shutdowns every 10 minutes if the inside temperature is at or below 69 °F (20 °C). The lower the temperature, the longer the compressor shutdown will last. In addition, the de-icing cycle algorithm will perform brief reverse cycle runs (with the fan purposely turned off) if the cooling cycle runs for 40 minutes without any cooling progress or if the cooling cycle runs for more than 60 minutes, regardless of cooling progress.

The parameter setting for the de-icing feature depends on whether you are using the optional inside air temperature sensor or the display built-in temperature sensor. Installation of an optional inside air temperature sensor (located in the return air path) greatly increases the effectiveness of the de-icing feature, and this option should be considered whenever the display sensor cannot read the room temperature accurately.

For additional details on parameter settings and navigation options, refer to “Selecting a Parameter” on page 15 and “Navigation Tree” on page 34.

7.2 Choosing the Control Operation



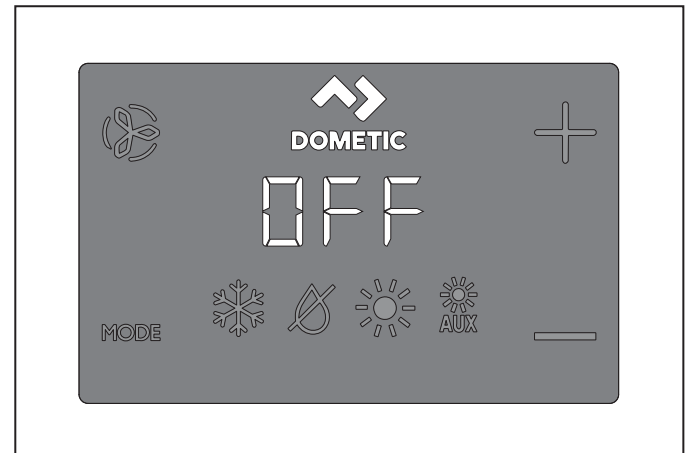





The four Mode indicators represent the different modes of the control: COOL, DEHUMIDIFICATION, HEAT, and AUX HEAT. Refer to “Using the Control Display Panel” on page 13 for more detail on mode operation.





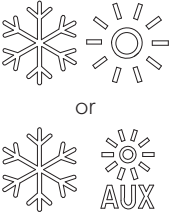

8 Choosing the Control Operation

1. Tap the **Mode** icon to select a mode. Refer to “Available Modes and Options for Operation” on page 12.
 - Display icons illuminate to indicate the selected mode.
 - The display locks into the last mode selected after five seconds of inactivity, then displays the room temperature. The selected mode LED remains lit.
 - After 10 seconds of inactivity, the display shows the room temperature and enters the IDLE state.
 - OFF displays on the screen to indicate the OFF state.
 - When the display is making a call for heating, cooling, aux heat, or humidity, the appropriate Mode indicator blinks for two seconds ON and two seconds OFF.
2. Tap any icon to wake up the control from the OFF or IDLE state.
3. Tap and hold the **Mode** icon for three seconds to initiate a SLEEP state.
 - The display goes dark.
 - Normal operation continues.
4. Tap and hold the **Mode** icon for an additional three seconds to wake up the control.







Available Modes and Options for Operation



Icon	Description/Mode	Function
	COOL	The COOL mode icon illuminates when the COOL mode is selected or when the unit is in an AUTOMATIC mode cooling cycle. Only the cooling system operates. If the ambient temperature drops below the set point, the system will not automatically switch to the HEAT mode.
	DEHUMIDIFICATION	<p>The DEHUMIDIFICATION mode icon illuminates when the DEHUMIDIFICATION mode is selected. This mode controls humidity during periods when the vessel is unoccupied and prevents the cabin temperature from dropping below the minimum default temperature setting.</p> <p>During humidity control:</p> <ul style="list-style-type: none"> • The fan circulates air for 30 minutes. • Air temperature is sampled and recorded. • After 30 minutes, a cooling cycle starts and continues until the temperature is lowered 2 °F (1 °C) or until the cooling cycle runs a maximum of one hour. • Four hours after the temperature is satisfied or the cooling cycle times out, the cycle repeats. <p>For temperature control:</p> <ul style="list-style-type: none"> • After the 30-minute fan circulation, if the sampled temperature is at or above the factory default setting 50 °F (10 °C), a cooling cycle begins and runs for humidity control. • If the temperature is below 50 °F (10 °C), a heating cycle begins. The heating cycle continues until the temperature reaches 50 °F (10 °C) or until the heating cycle runs a maximum of one hour. • Four hours after the temperature is satisfied or the cooling/heating cycle times out, the cycle repeats, each time determining whether cooling or heating is required. <p>i For DX systems only: the DEHUMIDIFICATION mode heat cycle will not run when the ambient temperature is below 40 °F (4 °C). This protects the condenser coil from freezing. Systems configured with electric heat will run the DEHUMIDIFICATION mode heat cycle regardless of the cabin temperature.</p>
	HEAT	The HEAT mode icon illuminates when the HEAT mode is selected or when the unit is in an AUTOMATIC mode heating cycle. Only the heating system operates. If the ambient temperature rises above the set point, the system will not automatically switch to the COOL mode.
	AUX HEAT	The AUX HEAT mode icon illuminates when the optional auxiliary electric heater is in operation. If the ambient temperature rises above the set point, the system will not automatically switch to the COOL mode.
	OFF	All control outputs are turned OFF. The display reads OFF. All settings are saved in non-volatile memory.
	ON	All control outputs are on and the display indicates the current state of operation. The display shows the cabin temperature. All parameters operate as set.
	AUTOMATIC	The AUTOMATIC mode icons illuminate when the system is in AUTOMATIC mode, which switches to cooling or heating as required to satisfy the temperature set-point. When AUTOMATIC mode is selected, the system provides both heating and cooling, as required. The COOL and HEAT indicators or COOL and AUX HEAT icons are illuminated according to the AUTOMATIC mode.
	Wi-Fi	Wi-Fi capable displays have the Wi-Fi icon on the display. Prior to connection, and after enabling parameter 30, the Wi-Fi icon on the displays flashes white approximately three times per second. Once the device is connected, the icon illuminates a solid white. Refer to “Using the CapTouch Wi-Fi Application” on page 21 for information on the full functionality of the Wi-Fi capability.

Icon	Description/Mode	Function
	Fan	<p>The Fan icon allows the user to cycle through all of the different fan speeds, which include auto and 1–5 (1=low, 2=medium low, 3=medium, 4=medium high, and 5=high). Fan speeds are automatic based on default and programmed values. Program menu settings P-1 and P-2 determine the maximum and minimum fan speed settings.</p> <ul style="list-style-type: none"> Fan speed decreases as the temperature set-point is approached in COOL mode and operates at low speed when the set point is reached. The automatic fan speed operation can be reversed for HEAT mode when parameter P-12 is set to "rEF". See "Programming the Control" on page 14 for more detail. Automatic fan mode determines the required fan speed based on temperature differential. This balances the most efficient temperature control with a slower, quieter fan speed. To select automatic fan mode, tap and release the Fan icon until an "A" appears on the display. <p>i Refer to "Selecting a Parameter" on page 15. Once high and low fan speed limits are set, the unit automatically readjusts the remaining fan speeds in both automatic and manual fan modes.</p>
	Manual Fan	<p>Manual fan allows the selection of a consistent desired fan speed. There are five manual fan speeds available: high, medium high, medium, medium low, and low. The speed number is illuminated on the display when selected.</p> <ul style="list-style-type: none"> Tap and release the Fan icon to advance from automatic to manual fan operation. Tap and release the Fan icon to cycle through the manual fan speeds, from low to high. Tap and release the Fan icon to return to automatic fan operation.
	Fan-Only	<p>Use fan-only to operate the fan for air circulation when no cooling or heating is desired.</p> <ul style="list-style-type: none"> From the OFF mode, tap and release the Fan icon to select a desired fan speed. <p>i Turning the control ON reverts the fan to the AUTOMATIC mode or the last selected manual fan setting.</p>
	Cycled / Continuous Fan	<p>The fan can be set to run continuously whenever the system is turned ON, or it can be set to cycle ON and OFF in conjunction with the cooling or heating cycles.</p> <ul style="list-style-type: none"> Tap and hold the Fan icon for five seconds. <ul style="list-style-type: none"> CYC displays when the operational setting is set to cycled. CON displays when the operational setting is set to continuous.

7.3 Using the Control Display Panel

The following table details the icon combinations to use to activate different functions on the control.

Icon Combination	Icon Names	Function
MODE & 	Mode & Up	Enter the programming menu: Tap simultaneously and hold for three seconds while the control is in the OFF mode. P1 appears on the display.
 & 	Up & Down	Display the outdoor temperature: Tap simultaneously and hold for three seconds. The display alternates between OU and the outdoor temperature reading while this combination is held.
 & 	Fan & Up	Display the seawater temperature: Tap simultaneously and hold for three seconds. The display alternates between SE and the seawater temperature reading while this combination is held.
 &  & MODE	Up, Down, & Mode	Display the relative humidity: Tap simultaneously and hold for three seconds. The display alternates between HS and the relative humidity reading while this combination is held.

Icon Combination	Icon Names	Function
	Mode & Down	Enter fault history: <ul style="list-style-type: none"> • Tap simultaneously and hold for three seconds while the control is in the OFF mode to enter the fault history log. The display holds up to eight faults. • Use the Up and Down icons to view the fault history. • Tap and hold the Mode and Down icons simultaneously for three seconds to clear the fault history. • Exit by tapping the Mode icon once.
	Fan & Down	DX Only: display the compressor run-time hour meter: <ul style="list-style-type: none"> • Tap simultaneously and hold for three seconds while the control is in the OFF mode. The display will show the code Hr one time and then shows the run time. • Exit by tapping the Mode icon once.

7.4 Programming the Control

i If your AC has a Shaded-Pole (SP) fan motor instead of a Split-Capacitor (SC) High-Velocity (HV) fan motor, program SP into the fan motor type parameter before operating the unit. Refer to “Programming the Control” on page 14. SP units are recognizable by an overhanging blower motor. The SC motor of an HV unit is inside the blower, and the unit has VTD or HV as part of the model number. Only reprogram the fan motor type parameter if you do not have an HV blower.

Parameter settings are used to program and fine-tune the system for the most efficient operation within an installation and to adjust operating parameters for your particular needs. After new values are entered and memorized, the factory defaults are overwritten and the new parameters become the default values.

Should the CapTouch lose power, the operating parameters are retained. When power is restored, the control resumes operating as last programmed.

The control has factory default values stored in permanent memory (memorized factory default settings) that can be recalled if you have any programming difficulties. You can restore the original factory default parameters manually. Refer to “Selecting a Parameter” on page 15 for a summary of the parameters, the permitted values, and original factory default settings.

7.4.1 Entering Programming Mode

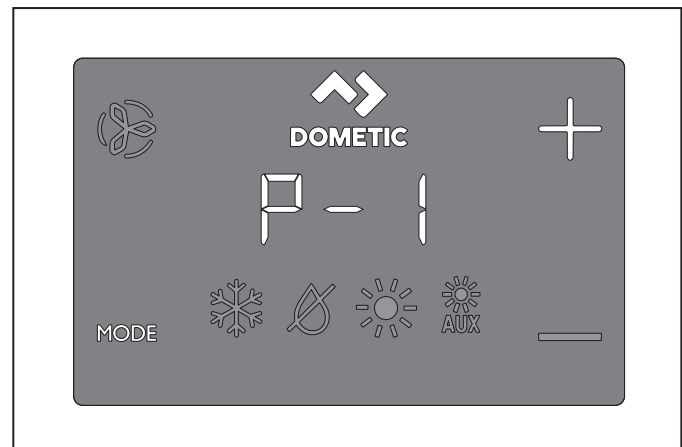

9 Entering Programming Mode

1. While the control is in the OFF mode, simultaneously tap and hold the **Mode** and **Up (+)** icons on the display screen for one second to enter the programming menu. P-1 appears on the display.
2. Use the **Up (+)** and **Down (-)** icons to navigate to different parameters (P-1, P-2, P-3, etc.).
3. Tap the **Mode** icon to enter the parameter adjustment menu. The display will alternate between the parameter number and the current setting.
4. Tap the **Up (+)** and **Down (-)** icons to adjust the parameter settings.
5. Tap the **Mode** icon to lock in the parameter change and return to the programming menu.



7.4.2 Selecting a Parameter



The following table describes the parameters available for the CapTouch controls.

Parameter	Name	DX	CW	Factory Default	Parameter Range
P-1	High Fan Limit	x	x	95	65–95
		Select a higher number to increase the fan speed, a lower number to decrease the fan speed.			
P-2	Low Fan Limit	x	x	50	30–75
		Select a higher number to increase the fan speed, a lower number to decrease the fan speed.			
P-3	Compressor Staging Time Delay	x		15	5–135 seconds
		Use for installations where more than one system operates from the same power source. Different staging delays allow compressors to start at different times when the power is interrupted. Stage the units at least five seconds apart.			
P-4	Inside Air Temperature Sensor Calibration	x	x	Ambient Temperature	Ambient Temperature ± 10 °F (6 °C)
		Calibrates the sensor to display the correct room temperature reading. The setting increments are in °F even when the control is set to display °C.			
P-5	Failsafe Level	x		3	0 = Minimal Protection 1 = Continuous No Display ¹ 2 = Continuous With Display ¹ 3 = Four Failures, Reset Required
		Refer to “Fail Safe Levels” on page 20. ¹ Applies to display firmware #40 and older.			
P-6	Low Voltage Monitor	x	x	OFF	OFF, 95 VAC/195 VAC
		Set the built-in voltmeter circuit that monitors the AC input voltage prior to each cooling or heating cycle when set to 95 VAC or 195 VAC. <ul style="list-style-type: none"> For 100–120 VAC input power, set to OFF or 95. For 208–240 VAC input power, set to OFF or 195. 			
P-7	De-icing Cycle	x		OFF	OFF 1 = ON with 5 °F (3 °C) Display Sensor Differential 2 = ON with 7 °F (4 °C) Display Sensor Differential
		Select the parameter setting for the de-icing feature depending on whether you are using the optional inside air temperature sensor or the display built-in temperature sensor. <ul style="list-style-type: none"> If using an optional inside air temperature sensor, set this parameter to 1 to turn the de-icing feature ON, or to OFF to disable. If using the display built-in temperature sensor, choose one of the two selectable behavior modes: <ul style="list-style-type: none"> 1: assumes the display sensor may be reading the room temperature as much as 5 °F (3 °C) greater than the actual evaporator temperature (standard). 2: for more extreme installations - assumes the display sensor may be reading the room temperature as much as 7 °F (4 °C) greater than the actual evaporator temperature. The setting of 2 should only be used if a setting of 1 does not prevent evaporator ice from forming. 			
P-8	Optional Pump Sentry	x		OFF	OFF ON = Select 100 °F to 150 °F (38 °C and 66 °C)
		Set this parameter setting when the optional pump sentry water sensor is installed to monitor the condenser coil temperature and to shut down the pump and compressor when the coil temperature rises above the programmed value. This sensor is plugged into the H2O OUT sensor jack on the control board. Program a temperature between 100 °F and 150 °F (38 °C and 66 °C), depending on seawater temperature and the system type. Refer to the sensor installation instructions. The setting increments are in °F even when the control is set to display °C.			

Parameter	Name	DX	CW	Factory Default	Parameter Range
P-9	Display Brightness Control	x	x	3	1 (Dimmest)–3 (Brightest) Set this parameter setting between 1 and 3. A dark cabin requires a setting of 1. A very bright cabin requires a setting of 3.
P-10	Fahrenheit or Celsius Selection	x	x	F	F = Fahrenheit Displayed C = Celsius Displayed A = Automatic Selection Based on Voltage 50 Hz = Celsius 60 Hz = Fahrenheit Select °C for Celsius (Celsius readings are displayed in tenths, for example 22.2°). The default setting is °F.
P-11	Cycle Pump with Compressor	x		CYC	CYC = Cycle with Compressor Con = Continuous Pump Select cycled or continuous pump operation. <ul style="list-style-type: none"> CYC: increases the pump life and conserves electricity by cycling ON and OFF with the compressor. Con: programs the pump to operate continuously whenever the system is on.
P-12	Reverse Automatic Fan Speeds During Heating	x	x	nOr	nOr = Normal Fan Operation rEF = Reversed Fan in HEAT Mode Reverse the automatic fan speeds during HEAT mode to improve heat output in cooler climates. <ul style="list-style-type: none"> When set to rEF, the fan speeds up as the set point is approached. The fan switches to low speed when the set point is satisfied and the water valve or compressor cycles OFF. When set to nOr, the fan operates the same as during cooling, which represents normal fan operation.
P-13	Cool-Only Mode	x		HP	HP = Heat Pump CL = Cool-Only Select heat pump or cool-only operation. <ul style="list-style-type: none"> Selecting "HP" operates the unit in the default heat pump mode, which allows for cooling, reverse cycle heating, or (optional) auxiliary electric heat. Selecting "CL" operates the unit in COOL or (optional) AUX HEAT modes. AUX HEAT mode is only available if the unit is equipped with an auxiliary electric heater. <p>i Selecting "CL" initiates a five-minute compressor delay when the compressor shuts down on the set point, a fault, or a power outage. The five-minute delay begins immediately after the compressor shuts down. The COOL mode icon on the display flashes once per second for five minutes or for the remaining time to complete the five minutes after the last cycle end time. If the five-minute delay period has passed before the compressor is called to operate, the compressor comes on with no delay.</p>
P-14	Fan Motor Selection	x	x	SC	SC = Split Capacitor Fan Motor SP = Shaded Pole Fan Motor Set to SC for AC switch high-velocity blowers. Set to SP if your unit has a Shaded Pole fan motor. Refer to "Programming the Control" on page 14 .
P-15	Restore Factory Default Settings	x	x	nOr	rST = Reset Defaults nOr = Normal To reset all programming parameters, set this parameter to rST. This restores all programmable parameters to the factory default values.
P-16	Hydronic Water Valve Forced Open		x	nOr	OPn = Valve Forced Open nOr = Normal Operation Open the water valve to bleed air from the system. <ul style="list-style-type: none"> OPn: forces the valve open for four hours while the control is turned OFF. If the control is turned ON or if AC power is interrupted during this four-hour period, the valve override is canceled. nOr: returns the valve to normal operation.

Parameter	Name	DX	CW	Factory Default	Parameter Range
P-17	Water Temperature Differential		x	15 °F (8 °C)	5 °F to 25 °F (3° C to 14 °C)
		<p>Set the temperature differential between the ambient air temperature and the hydronic water temperature that controls the water valve. For example, selecting 10 °F (-12 °C) opens the valve when the water temperature is 10 °F (-12 °C) less than the ambient temperature in the cooling mode and 10 °F (-12 °C) greater than the ambient temperature in the heating mode.</p> <p>Careful selection of the temperature differential can fully utilize the ship's heating and cooling resources. For example, while in cooling mode and using a 10 °F (-12 °C) value, the valve will open to allow some cooling while the hydronic system is coming down to temperature.</p>			
P-18	Air Filter Cleaning/ Replacement Timer Setting	x	x	0	Displays the elapsed time (in hours x10) since the timer was started or reset.
		<p>Establish a reminder to clean or replace the air filter. Ar/FL flashes briefly on the LED display every 10 seconds until it is cleared.</p> <ul style="list-style-type: none"> The parameter entered represents that number times 10 hours. Select the number of operating hours until the filter reminder appears. Parameter choices are between 10 (100 hours) and 250 (2500 hours). Tap the Down icon to reset the value to 0, restart the timer, and clear the reminder. <p> Dometic recommends checking the air filter at least every 500 hours of operation.</p>			
P-19	Filter Cleaning/ Replacement Timer Value & Reset	x	x	0	Displays the elapsed time (in hours x10) since the timer was started or reset.
		<p>Display the current elapsed time (in hours x 10) since the timer was started or reset. When this parameter value reaches the value set in parameter P-18, Ar/FL flashes on the display every 10 seconds until cleared. Tap the Down icon to reset the value to 0, restart the timer, and clear the reminder.</p>			
P-20	CAN Bus Unit ID	x	x	dIS (Unit ID = 59 (after enabling and power cycling)	0-255
		<p>Enables all units with a CAN Bus adapter installed to be networked together and communicate with each other or the ship's CAN Bus system (with additional translator equipment in some cases).</p> <ul style="list-style-type: none"> To enable the functionality, set the parameter to 0. Allow the display to revert to OFF mode. Power cycle the system. Once the system powers on, the CAN Bus Unit ID will be set to 59. Enter the unit's CAN Bus Unit ID number. 			
P-21	CAN Bus Group ID	x	x	58 (after enabling and power cycling)	0-255
		<p>Enables all units with a CAN Bus adapter installed to be grouped together in a network system and communicate with the ship's CAN Bus system (with additional translator equipment in some cases).</p> <ul style="list-style-type: none"> When parameter P-20 is disabled, the Group ID displays 1. Once the CAN Bus Unit ID is set to 0 and the power is cycled, the CAN Bus Group ID defaults to 58. Complete the steps in parameter P-20, then enter the unit's CAN Bus Group ID number. 			
P-22	Voltage Calibration	x	x	AC Voltage	Adjust to match the accurate voltage reading.
		<p>Displays a live reading of the voltage being read by the circuit board. Calibrating this parameter provides a more accurate voltage level when calculating low voltage for parameter P-6. Use a reliable voltmeter during adjustment.</p>			
P-23	Set Point Temperature Differential	x	x	2	1 = 1 °F (.6 °C) Differential 2 = 2 °F (1 °C) Differential
		<p>Set the temperature differential in Fahrenheit for all modes of operation: AUTOMATIC, COOL, HEAT, or AUX HEAT. Refer to "Choosing the Control Operation" on page 11 .</p> <ul style="list-style-type: none"> 1: maintains the room temperature ±1 °F (0.6 °C) from the desired set point. 2: maintains the room temperature ±2 °F (1 °C) from the desired set point. 			

Parameter	Name	DX	CW	Factory Default	Parameter Range
P-24	DEHUMIDIFICATION Mode Minimum Temperature	x	x	50 °F (10 °C)	40 °F to 75 °F (4 °C to 24 °C)
		Set the minimum room temperature (in Fahrenheit) for which DEHUMIDIFICATION mode initiates a cooling cycle to remove moisture from the air. If the room temperature is below this parameter setting, DEHUMIDIFICATION mode runs a heating cycle. Refer to “Choosing the Control Operation” on page 11.			
P-25	Auto Fan Speed Temperature Differential	x	x	2 °F (1 °C)	1 °F to 3 °F (0.6 °C to 2 °C)
		Set the incremental differential (with cumulative steps) between the ambient temperature and the set point temperature at which the fan speed will increment to the next speed.  A 1 °F (0.6 °C) hysteresis in the auto fan speed differential prevents the speed from changing if the room temperature changes. In addition, programming parameters P-12 and P-23 both have an effect on the operation of the auto fan speed.			
P-26	Supply Air High Temperature Limit	x	x	OFF	OFF 95 °F–140 °F in 5° increments (35 °C–60 °C in 2.8° increments)
		Set the maximum supply air-discharge temperature allowed. <ul style="list-style-type: none"> Enabling this parameter has no effect unless parameter P-28 is enabled and set to EnA. Use of this parameter requires that the OAT sensor be placed in the supply air stream immediately downstream of the blower discharge. HEAT mode shuts down if the temperature of this sensor exceeds the setting. HEAT mode is restored when a 10 °F (6 °C) hysteresis is satisfied or when power is cycled to the control and the OAT sensor temperature is less than the setting but still within the hysteresis. SAH is displayed when this fault occurs. Display the discharge temperature by tapping the Up and Down icons simultaneously (same as viewing the outside air temperature). 			
P-27	Idle State Delay	x	x	10 seconds	5–120 seconds (5-second increments)
		Set the delay time before the display enters an idle state. Refer to “Choosing the Control Operation” on page 11. Use the Up or Down icons to increase or decrease the idle delay time.			
P-28	Auxiliary Heat Enable	x	x	dIS	dIS/EnA
		Enable the operation of an optional auxiliary electric heater. If an auxiliary electric heater is installed, change this setting to EnA to allow the auxiliary electric heater to be operated independently of the reverse-cycle heating. In DX applications, the auxiliary electric heat and compressor outputs on the control board operate at the same time only when the dehumidification functionality is active. Refer to “Relative Humidity Enable” in this table.			
P-29	Relative Humidity Enable	x	x	OFF	OFF / 50–80
		Enable the optional room temperature/relative humidity combination sensor. This allows the system to dehumidify using auxiliary electric heat (if an auxiliary electric heater is installed and enabled) when the cabin humidity rises above the selected relative humidity (RH). <ul style="list-style-type: none"> For DX applications: Relative humidity enabled. If the optional room temperature/relative humidity combination sensor is connected to the control board and senses that the humidity has increased, the compressor run time will extend by operating to 1 °F lower than the set point to remove the humidity. If an auxiliary electric heater is installed, it will cycle ON and OFF to maintain the set point while the compressor stays on longer to dehumidify.  There could be a period of overlap when the compressor and the auxiliary electric heater are on at the same time. This cycle continues until the cabin’s relative humidity is less than the humidity set point. The range of adjustment for the relative humidity is 50% to 80% RH. For CW applications: Relative humidity enabled. If the room temperature/relative humidity combination sensor is connected to the control board, this feature allows the system to dehumidify with electric heat (if an auxiliary electric heater is installed and enabled) when the cabin humidity rises above the humidity set point. The auxiliary electric heater will cycle ON and OFF to maintain the set point while the bypass valve opens to allow cold loop water to enter the air handler coil to dehumidify. This operation continues until the cabin’s relative humidity is less than the humidity set point. If an auxiliary electric heater is not installed, the on time of the bypass valve will extend by operating to 1 °F lower than the set point. This cycle continues until the cabin’s relative humidity is less than the humidity set point. The range of adjustment for the relative humidity is 50% to 80% RH. 			

Parameter	Name	DX	CW	Factory Default	Parameter Range
P-30	Wi-Fi Connectivity	x	x	DIS	
		Available only in Wi-Fi capable displays, indicated by the Wi-Fi icon on the display. Refer to “Using the CapTouch Wi-Fi Application” on page 21 for detail on the full functionality of the Wi-Fi capability.			
P-31	Seawater Low-Limit Adjustment	x		40 °F (4 °C)	35 °F to 50 °F (2 °C to 10 °C)
		<p>If the optional seawater low-limit adjustment sensor is connected to the control board H2O Out 2-pin plug, set the system to switch from reverse-cycle heat to auxiliary electric heat (if an auxiliary electric heater is installed and enabled).</p> <ul style="list-style-type: none"> Adjustment occurs when the seawater temperature drops below 40 °F (4 °C) and the reverse-cycle heat has been in operation for more than five minutes. Once the seawater rises 3 °F above the seawater low-limit adjustment sensor temperature set point, the system returns to reverse-cycle heating. If an auxiliary electric heater is not installed, the system will shut down and flash LO then SE when the seawater drops below 40 °F (4 °C) (default). Once the seawater rises 3 °F above the seawater low-limit adjustment sensor temperature set point, the system automatically goes back into reverse-cycle heating and stops flashing LO then SE. 			
P-32	Humidity Sensor Calibration	x	x	Ambient Relative Humidity	Ambient Relative Humidity ±10%
		<p>Calibrate the room temperature/relative humidity combination sensor to display the correct room humidity reading.</p> <p> This setting is applicable to software revision #42 and newer only.</p>			
P-33	Water Inlet Temperature Sensor Calibration	x	x	CW = Supplied Chilled Water Temperature DX = Condenser Coil or Seawater Temperature	CW = Supplied Chilled Water Temperature ±10 °F (6 °C) DX = Condenser Coil or Seawater Temperature ±10 °F (6 °C)
		<p>Calibrate the Water Out (DX) or Water In (CW) temperature sensor to display the correct water temperature reading. The setting increments are in °F even when the control is set to display °C.</p> <p> This setting is applicable to software revision #42 and newer only.</p>			
P-34	OAT Sensor Calibration	x	x	Outside Ambient Temperature	Outside Ambient Temperature ±10 °F (6 °C)
		<p>Calibrate the outside ambient air temperature sensor to display the correct outside air temperature reading. The setting increments are in °F even when the control is set to display °C.</p> <p> This setting is applicable to software revision #42 and newer only.</p>			

7.4.3 Exiting programming mode

To exit the programming menu manually, simultaneously tap and hold the **Up (+)** and **Mode** icons for three seconds until the room temperature is displayed. Alternatively, the display automatically exits the programming menu after 10 seconds of inactivity.

The control’s software version (such as “40”) appears in the display for one second prior to the manual or automatic exit from the programming mode. The control enters OFF mode after exit.

7.4.4 Identifying Programming Fault Codes

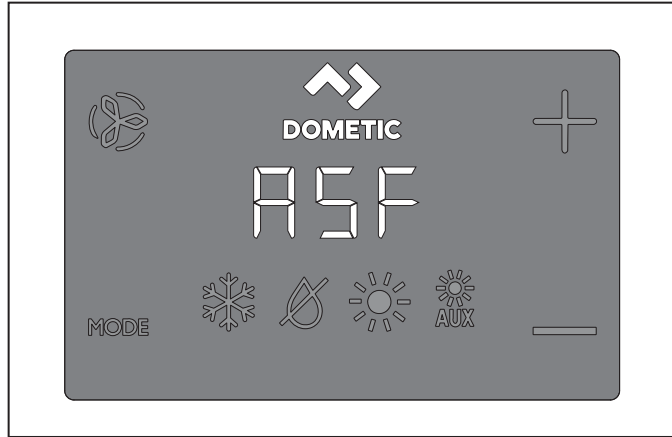

10 Identifying Programming Fault Codes

To protect the unit, certain fault conditions trigger a lockout that shuts down the control. The control will not restart until the fault is repaired. The type of lockout associated with the fault depends on the type of fault detected (refer to the Fault and Status Codes table) in combination with the level of protection (refer to the Fail Safe Levels table) that was programmed in the P-5 parameter (refer to “Selecting a Parameter” on page 15).

Fault and Status Codes

Code	Description	DX	CW
HPF	High Pressure Switch Fault: indicates high refrigerant pressure. This fault is not applicable in HEAT mode.	x	
LPF	Low Pressure Switch Fault: indicates low refrigerant pressure. This fault has a three-minute shutdown delay (for display firmware #41 and newer).	x	
PLF	Low Pump Flow Fault: indicates high-water temperature in the condensing coil or low pump flow.	x	
IL/--	Indicates a loop water sensor failure		x
IS/--	Inside Sensor: indicates the display built-in temperature sensor is damaged.	x	x
Ar/FL	Indicates the air filter replacement timer has expired.	x	x
SAH	Indicates a high supply air temperature limit.	x	x
SLP	Indicates Sleep or Lock mode. Buttons do not function in these modes.	x	x
LO/SE	Indicates a seawater low limit.	x	x

Code	Description	DX	CW
LO/AC	<p>Low Voltage Fault: indicates low voltage. This fault offers extra protection for the compressor and components within the system during low-voltage (brownout) conditions:</p> <ul style="list-style-type: none"> After the compressor starts, the low voltage monitor checks the AC input voltage. If voltage drops below the specified setting (95 VAC/195 VAC) and remains below for three minutes, the system shuts down and the low AC voltage fault displays. The fault continues until the AC input voltage rises above 95 VAC/195 VAC. Then, the LO/AC fault code clears automatically and the cooling or heating cycle commences. 	x	x

Fail Safe Levels

Lvl	Description	DX Only
0	<p>Fail Safe Level 0: Temporary failsafe, limited to five-minutes. The system will automatically switch back to Level 3 after five minutes (only in display firmware #41 and newer). Provides minimal failsafe protection and is not recommended.</p> <ul style="list-style-type: none"> Only the IS/-- fault is detected and displayed. The control shuts down and will not restart until the fault is repaired. Once repaired, the control restarts after a two-minute delay. 	
1	<p>Fail Safe Level 1 (only for display firmware #40 and older): includes the failsafe actions of the previous level and detects all other faults, but they are not displayed.</p> <ul style="list-style-type: none"> The system shuts down for two minutes or until the fault is cleared, whichever is longer. The system restarts when the fault is cleared. 	x
2	<p>Fail Safe Level 2 (only in display firmware #40 and older): includes the failsafe actions of the previous levels and displays all other faults.</p> <ul style="list-style-type: none"> The system shuts down for two minutes or until the fault is cleared, whichever is longer. The system restarts when the fault is cleared. 	
3	<p>Fail Safe Level 3: includes the failsafe actions of previous levels and the system will lockout after four consecutive HPF, LPF or PLF faults. In addition, the lockout can be cleared.</p> <ul style="list-style-type: none"> The system shuts down for two minutes or until the fault is cleared, whichever is longer. To clear the lockout, enter OFF mode. Then, return to ON mode. 	

7.5 Using the CapTouch Wi-Fi Application

The CapTouch Wi-Fi application (CapTouch App) is a Dometic-created smart device application that allows Wi-Fi connectivity to the CapTouch Wi-Fi thermostat.

Users can download and install the application from the currently supported platforms at Google Play or Apple Store.

1. Search for Dometic apps on the appropriate platform.
2. Download the app with the CapTouch Wi-Fi logo:



11 Identifying the CapTouch Wi-Fi Logo

Once downloaded, use these instructions to create a user account and to add one or more thermostats to an account.

7.5.1 Opening the CapTouch Wi-Fi App

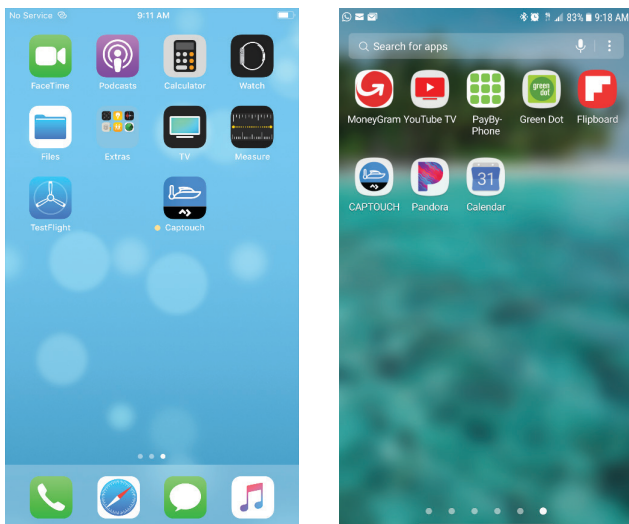

12 Searching Available Application Screens

1. Locate the CapTouch logo in the list of available applications on your smart device.

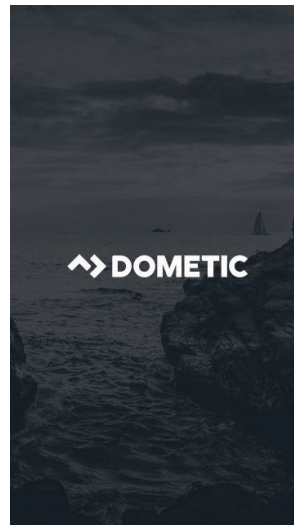

13 Opening the CapTouch Wi-Fi App

2. Tap the logo to open the CapTouch App. A splash screen displays indicating the app is loading.

7.5.2 Creating an Account

First-time CapTouch App users must set up an account for new installations.

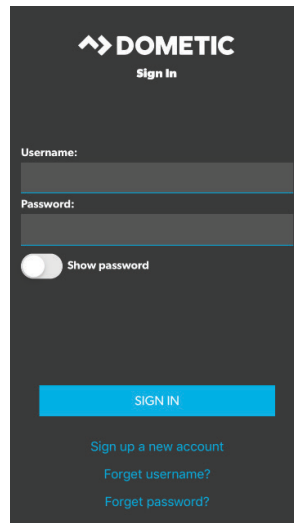

14 Using the Sign In Screen

1. Tap **Sign up a new account** for new installations or input a username and password to access an existing account.

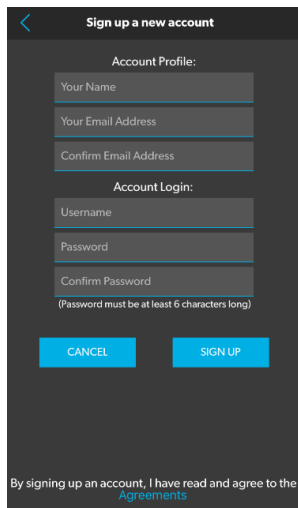

15 Inputting Account Information

2. Enter the requested information for the Account Profile and the Account Login.
- i** Keep your username and password in a secure location for future reference.
3. Read and accept the Agreements.
4. Tap **Sign Up**.

7.5.3 Recovering a Username or Password

Once your account is set up, your chosen username and password are tied to the account. If you lose your username or password, it can be recovered through the Sign In screen.

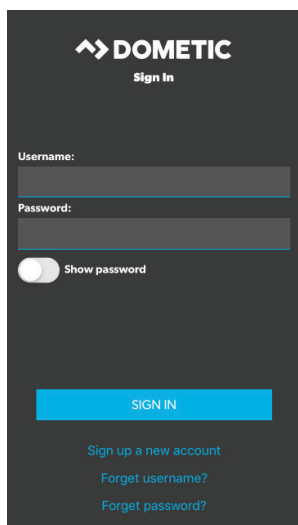

16 Choosing a Recovery Option

1. Select **Forgot username?** or **Forgot Password?**.

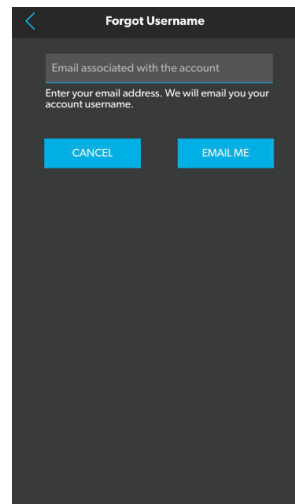

17 Recovering a Username Example

2. Enter your email address.
3. Tap **EMAIL ME**.
The Sign In screen displays and an email with the requested information is forwarded to the address provided.

7.5.4 Using the CapTouch App Menu

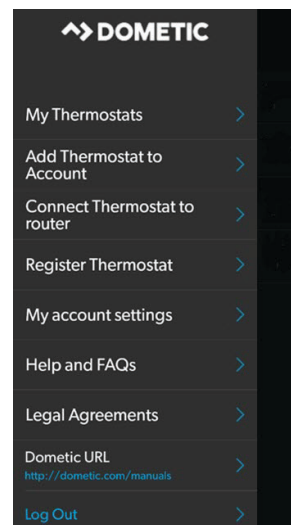

18 Using the CapTouch App Menu

The CapTouch App defaults to a list of your existing thermostats, which need to be added for a new application installation. To access the CapTouch App menu options, tap . A menu list appears. Select the option that supports the action you wish to perform.

Menu Option	Description
My Thermostats	Shows the list of thermostats currently associated with the user account.
Add Thermostat to account	Opens the screen for adding a thermostat to the account.
Connect Thermostat to router	Opens the in-app instructions for connecting a thermostat to an existing wireless router.
Register Thermostat	Opens the registration screen to register your CapTouch devices for remote control using the CapTouch App.
My account settings	Allows a user to change or update the main email address and password associated with the account.
Help and FAQs	Provides basic information about the application and its functionality.
Legal Agreements	Provides access to the legal agreements of the account.
Dometic URL	Accessing this menu item takes the user directly to the online user manual database on the Dometic website.
Log Out	Signs the user out of the CapTouch App.

7.5.5 Locating the Device ID and Claim Code

The device ID and claim code are important when adding a thermostat to the CapTouch App. The device ID and claim code combinations are unique to each thermostat. If the device ID and claim code do not match the thermostat, the thermostat cannot be added to an account.

To locate the device ID, access programming parameter 30 and tap the **Up** arrow or **Down** arrow until the ID appears. The claim code appears one tap above or below the device ID. Refer to "Programming the Control" on page 14.

7.5.6 Adding a Thermostat

The device used to add a thermostat to the account must be connected to the Internet or the thermostat will not be registered in the Cloud.

i Prior to adding a thermostat, locate the Device ID. Refer to "Locating the Device ID and Claim Code" on page 23.

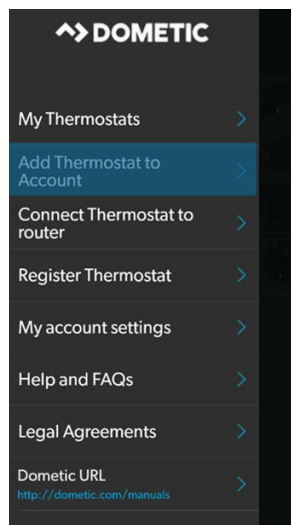

19 Adding a Thermostat

1. Open the CapTouch App.
2. Tap .
3. Select **Add Thermostat to account**.

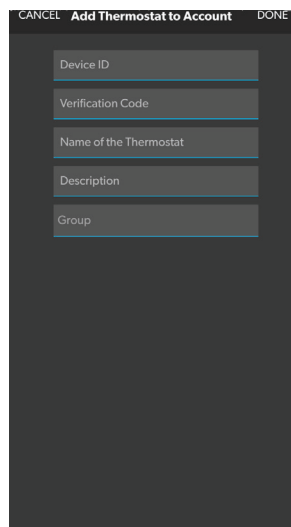

20 Entering Device Information

4. Enter the following information:
 - **Device ID**
 - **Name of the thermostat**
 - **Description** (area or room)
 - **Group** (not required)

i If there are no groups available when populating **Group**, a pop-up window opens with these options:

- **- Not to assign at this time**
- **+Add a new group**

- **Done** (iOS)/**Cancel** (Android)

When selecting **+Add a new group** the CapTouch App displays the Add a New Group screen. When selecting **Cancel** or **Done**, the screen remains in the Add Thermostat to account screen.

5. Tap **Done**.

Once the thermostat is added to the account, the CapTouch App returns to the list of thermostats and automatically places the new thermostat on the main screen.

- i** If a disconnected thermostat is selected from the thermostat list, an “Information is not current. Device has been off-line” pop-up message appears. Tap **OK**.

Access the menu options from the main screen to connect a thermostat to a wireless router.

7.5.7 Connecting the Thermostat to a Wireless Router

- i** Make sure that a wireless router is set up and available for connection.

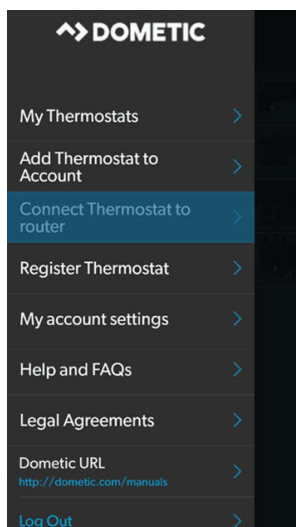

21 Connecting the Thermostat to a Wireless Router

The CapTouch App displays these instructions in-app. Follow these instructions for each thermostat added to the account.

1. Register the thermostat to make sure that the ID is valid and available. A security verification appears confirming the registration.

- i** Registration must be done while the smart device is connected to the Internet and before the thermostat is in AP mode.

2. Open the CapTouch App.
3. Tap .
4. Select **Connect Thermostat to router**.

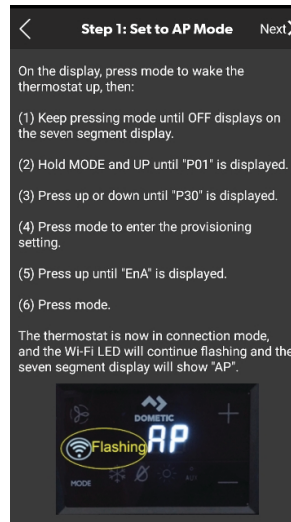

22 Following Step 1 of the In-App Instructions

5. Complete Step 1: Set to AP Mode.
 - a. Tap **Mode** on the thermostat to activate the display.
 - b. Tap **Mode** until the display enters OFF mode.
 - c. Tap **Mode** and **Up** (+) simultaneously until P01 appears.
 - d. Use the **Up** (+) and **Down** (-) icons simultaneously until P30 appears.
 - e. Tap the **Mode** icon to enter the parameter adjustment menu.
 - f. Tap **Up** (+) until EnA appears.
 - g. Tap **Mode**. AP appears on the display.
- i** Once Wi-Fi parameter 30 is enabled, the Wi-Fi icon on the thermostat flashes white three times per second until a connection is established.

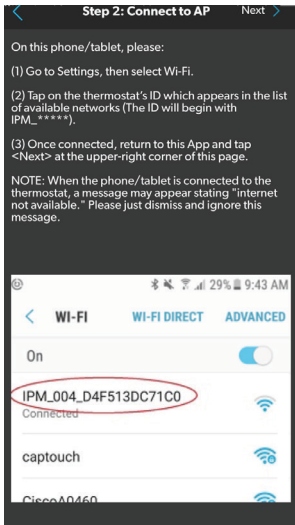

23 Following Step 2 of the In-App Instructions

6. Complete Step 2: Connect to AP.
 - a. Go to the settings on your smart device and select **Wi-Fi**.
 - b. Select the thermostat ID from the list of available networks. The thermostat ID will begin with IPM_.
 - c. Once the thermostat ID and smart device are connected, return to the CapTouch App.
-  An "Internet is not available" message may appear. Dismiss the notification.
- d. Tap **Next >**.

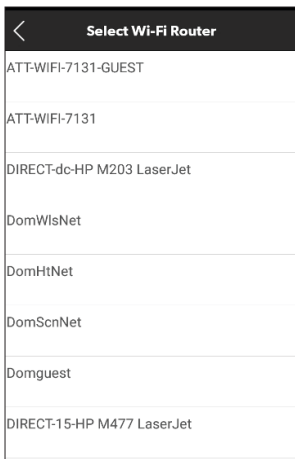

24 Choosing a Router from Your Network Setup

7. Select a router.

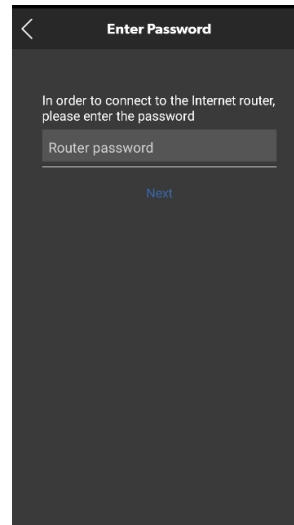

25 Entering a Password

8. Enter the password to access the wireless network.

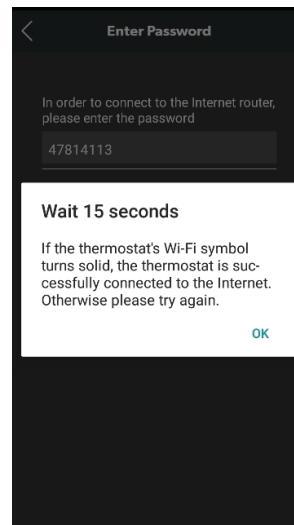

26 Connecting the Router

The thermostat and router begin the connection process. A message appears indicating the connection could take up to 15 seconds to establish. Tap **OK**.

The Wi-Fi icon on the thermostat illuminates a solid white color upon successful connection. The CapTouch App reverts to the list of thermostats.

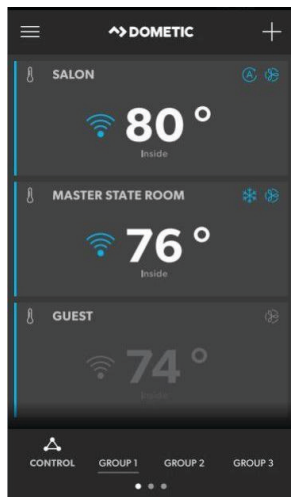

27 Viewing the Main Screen after Connection

- Repeat the connection process for each thermostat to be added to the account.

7.5.8 Viewing the Connection Modes

There are three ways that the CapTouch App indicates a smart device connection to the network.

Icon Displayed	Description
	The smart device is using only the cellular network to connect.
	The smart device is in the same Wi-Fi network as the thermostat, but there is no Internet connectivity. Only local connectivity exists between the smart device and the thermostat.
	The smart device is in the same Wi-Fi network as the thermostat and there is Internet connectivity.

7.5.9 Controlling and Changing Settings on a Thermostat

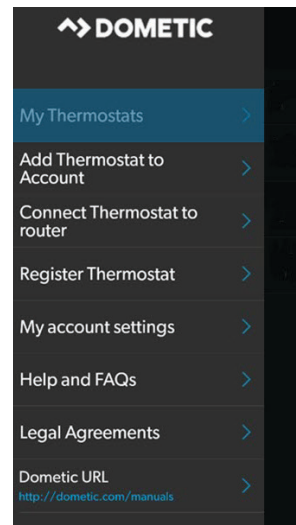

28 Controlling and Changing Settings on a Thermostat

- Open the CapTouch App.
- Tap
- Select **My Thermostats**.
A list of existing configured thermostats appears.

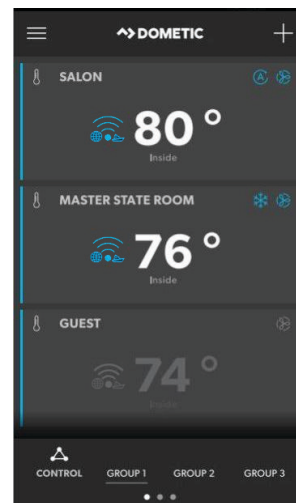

29 Viewing the List of Thermostats

- Select the thermostat to change.
The main thermostat status screen displays.

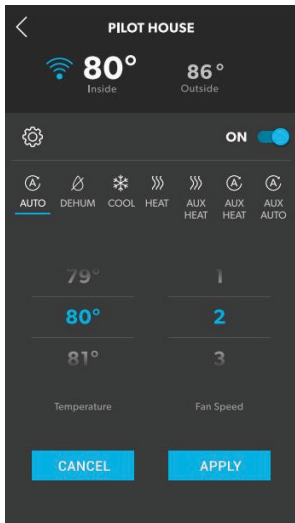

30 Viewing the Thermostat Status

5. Perform an action.

- Change a mode
- Change the temperature setting or fan speed
- Access the thermostat settings

Complete the following steps to change a mode:

1. Select a mode.
 - AUTOMATIC
 - DEHUMIDIFY
 - COOL
 - HEAT
 - AUX HEAT
 - AUX HEAT (AUTO)
 - AUX AUTO

i The DEHUMIDIFY mode requires the use of a humidity sensor recognized by the system and runs automatically without user selection. DEHUMIDIFICATION mode (Refer to “Choosing the Control Operation” on page 11) is based on a temperature setting and is time-based for running a cycle.

2. Tap **Apply**.

Complete the following steps to change the temperature or fan speed:

1. Scroll up or down in the numbered column above the setting to be changed to reach the desired value.

2. Tap **Apply**.

Complete the following steps to access the thermostat settings:

1. Tap the gear icon at the top of the status screen.

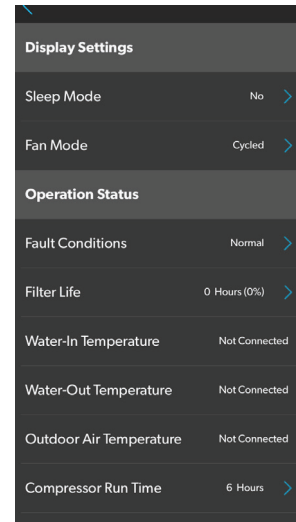

31 Viewing the Thermostat Settings

2. Tap a setting to view or change the thermostat status for that setting. Refer to “Selecting a Parameter” on page 15 for details on the settings.

7.5.10 How to Change/Add a Group

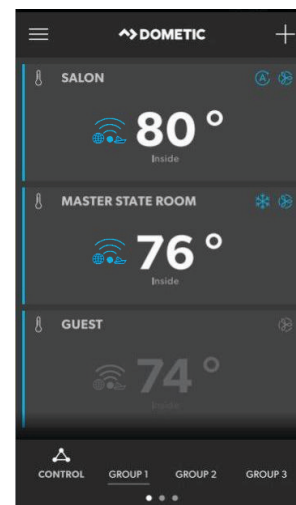

32 Changing or Adding a Group

1. Tap **Control** to display the list of groups available or to add/create another group.
2. Select a grouping from the main screen. The Group screen appears.

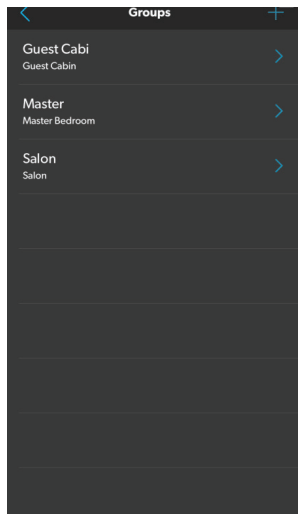

33 Viewing Available Groups

3. Tap the Group to be changed.
 - Tap **All** to make changes to all of the thermostat groups at once.
 - Tap **+** to add a group.

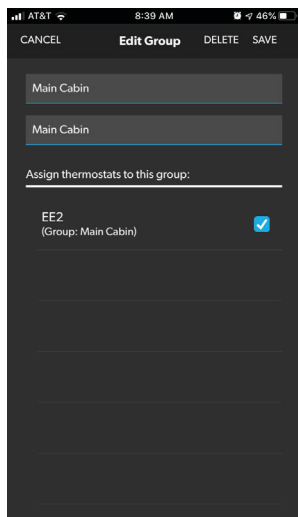

34 Updating the Information

4. Update the information, as needed.
5. Tap **Save**.

7.5.11 Adding a Thermostat to a Group

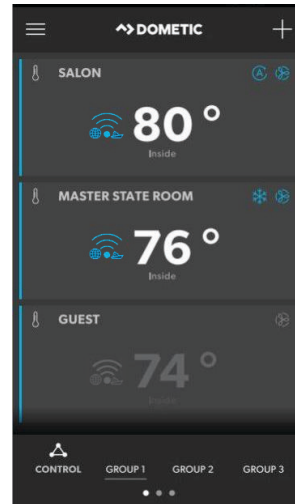

35 Adding a Thermostat to a Group

1. Tap **Control** to display all available groups. The Group screen appears with a list of available groups.

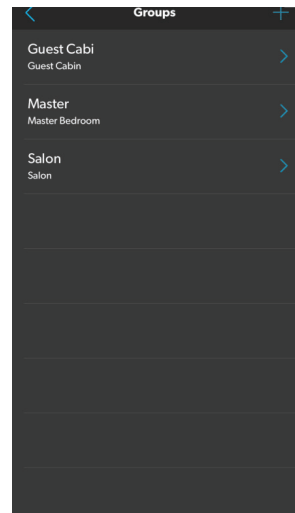

36 Selecting a Group

2. Select a group for the thermostat.
3. Select the check box next to the thermostat to be assigned to the group.
4. Tap **Save**.

7.6 Registering a Thermostat

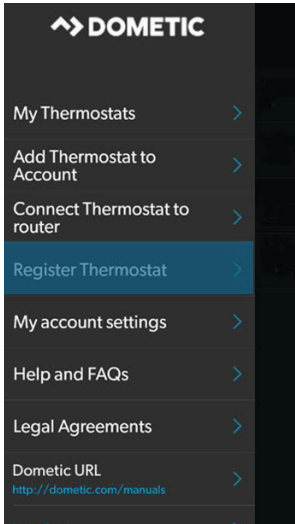

37 Registering a Thermostat

1. Open the CapTouch App.
2. Tap .
3. Select **Register Thermostat**.
A list of existing configured thermostats appears.

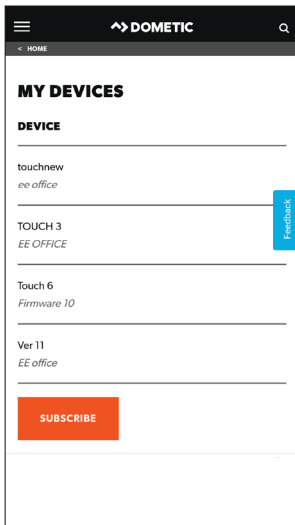

38 Viewing a List of Configured Thermostats

4. Tap **Subscribe**.
A subscription screen appears.

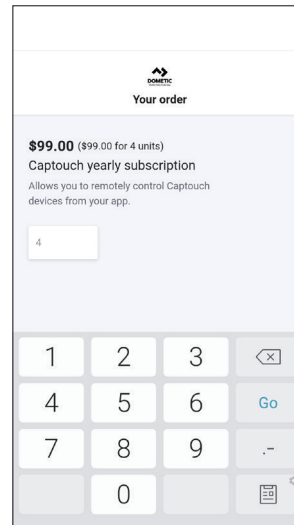

39 Selecting the Plan Devices

5. Enter the number of CapTouch devices you wish to control. The number of devices determine the subscription plan and cost.

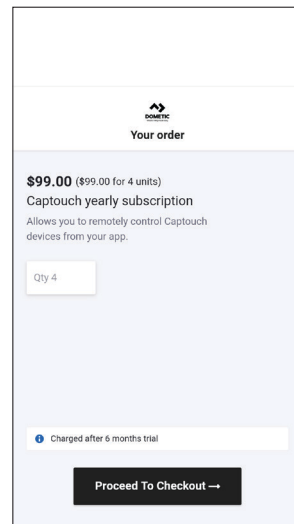

40 Purchasing the Subscription

6. Tap **Proceed to Checkout** to pay for the subscription.
Toggle buttons appear next to your configured thermostats.

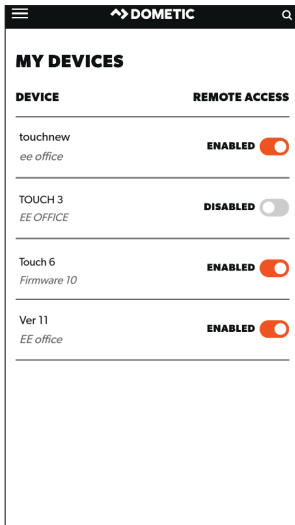

41 Enabling a Thermostat

7. Tap the toggle button next to a thermostat name to enable the thermostat and register it under your subscription.

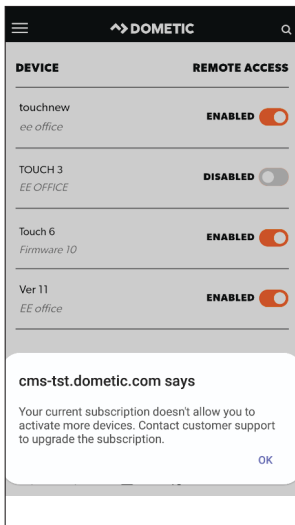

42 Receiving a Thermostat Activation Message

If you receive a message when enabling a thermostat, your subscription may not support the number of active devices registered to your account.

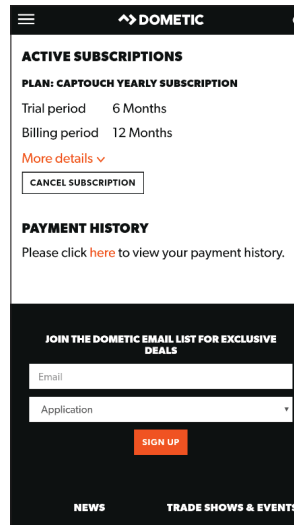

43 Viewing the Subscription Status and Payment History

8. Scroll down on your screen to view your active subscription status or to open your payment history.
9. Tap **More details**.
Details on the payment method, subscription period, and billing appear.

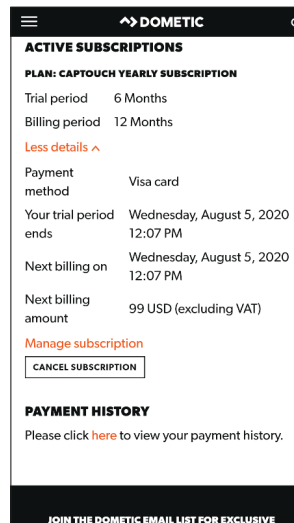

44 Viewing Account Details

10. Tap **Manage subscription** to access other options.
11. Tap **CANCEL SUBSCRIPTION** to cancel your subscription.
12. Tap the link under Payment History to see your invoices.
13. Tap  to visit other areas of the Dometic website and exit the billing and registration section.

7.7 Managing An Active CapTouch Subscription

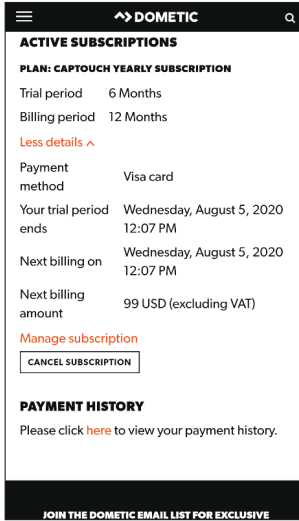

45 Managing the Subscription

1. Repeat steps 1–3 in “Registering a Thermostat” on page 29.
2. Tap **More details**.
3. Tap **Manage subscription**.
A login screen appears.

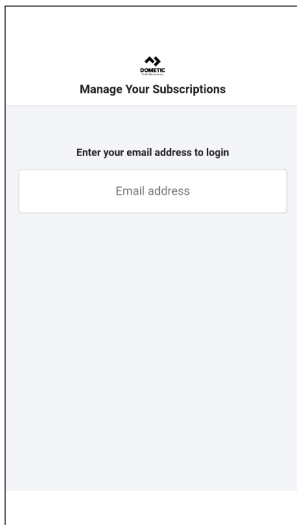

46 Entering the Subscription Login

4. Enter the email address tied to the subscription account.
The password screen appears.

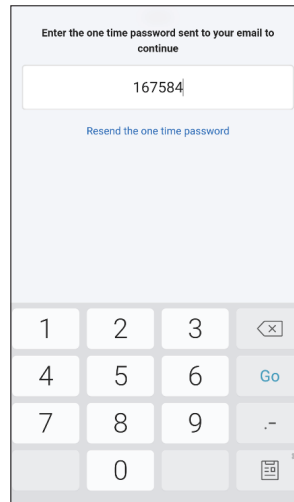

47 Entering the Password

5. Perform one of the following actions:
 - a. Enter the password.
 - b. Tap **Resend the one time password** to have the password sent to the email associated with the subscription.

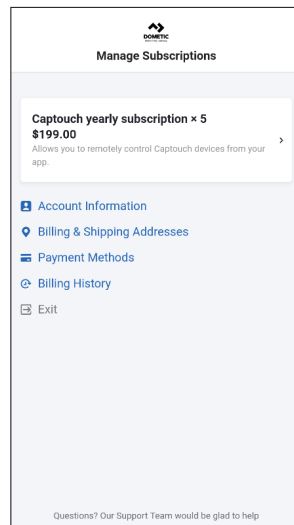

48 Viewing the Manage Subscription Screen Options

The Manage Subscriptions screen appears.

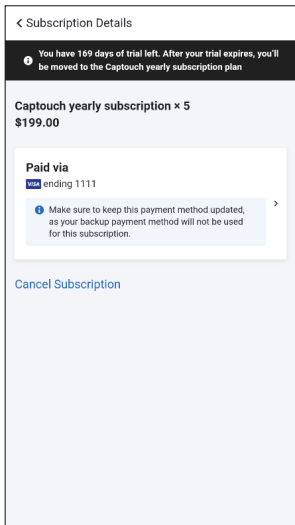

49 Viewing the Subscription Details

6. Tap the arrow next to the subscription summary to view the subscription details.
7. Tap **Cancel Subscription** to cancel your subscription. A confirmation screen appears.

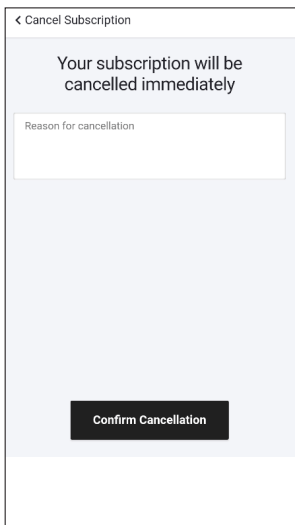

50 Confirming a Cancellation

- a. Enter the reason for cancellation and tap **Confirm Cancellation**.

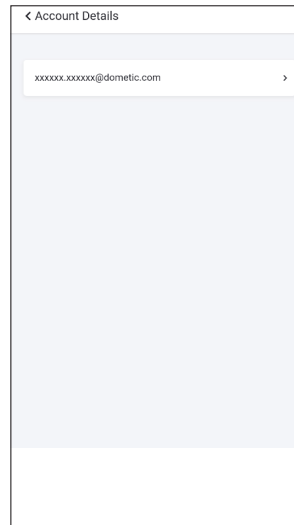

51 Selecting Account Information

8. Select **Account Information** to view the contact email address.

This email serves as a point of contact for any notifications, password pin resets, or other correspondence tied to the account.

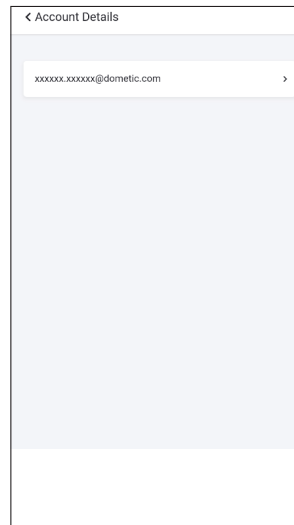

52 Updating Account Information

- a. To update the contact email address, tap the email address.
- b. Tap **Update**.
- c. Enter the desired email address.

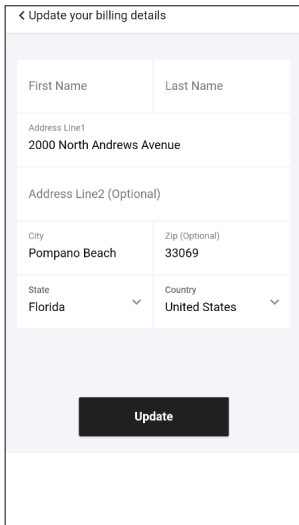

53 Updating Billing and Shipping Addresses

9. Select **Billing & Shipping Addresses** to view the billing details.

Tap **Update** to edit the information.

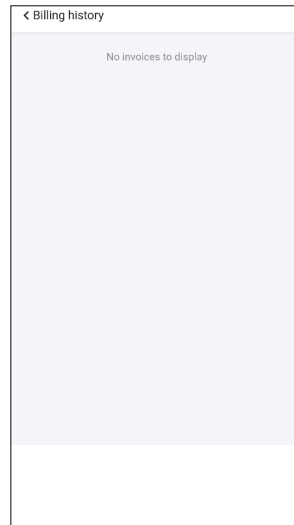

55 Viewing the Billing History

11. Select **Billing History** to view account invoices.

12. Select **Exit** to sign out of the manage subscription site and return to the list of configured thermostats.

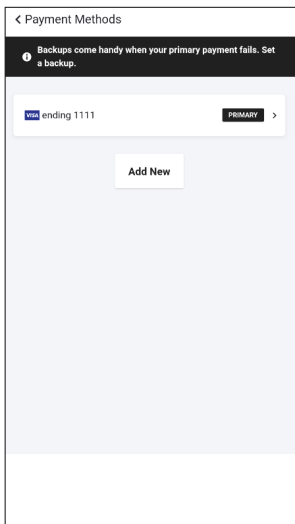

54 Adding Payment Methods

10. Select **Payment Methods** to view the payment information.

Tap **Add New** to include an additional credit card on the account.

i Although multiple credit cards can be added to the account, only one can be marked as the primary card for the account.

7.8 Navigation Tree

This section shows the menu navigation for the CapTouch Control.

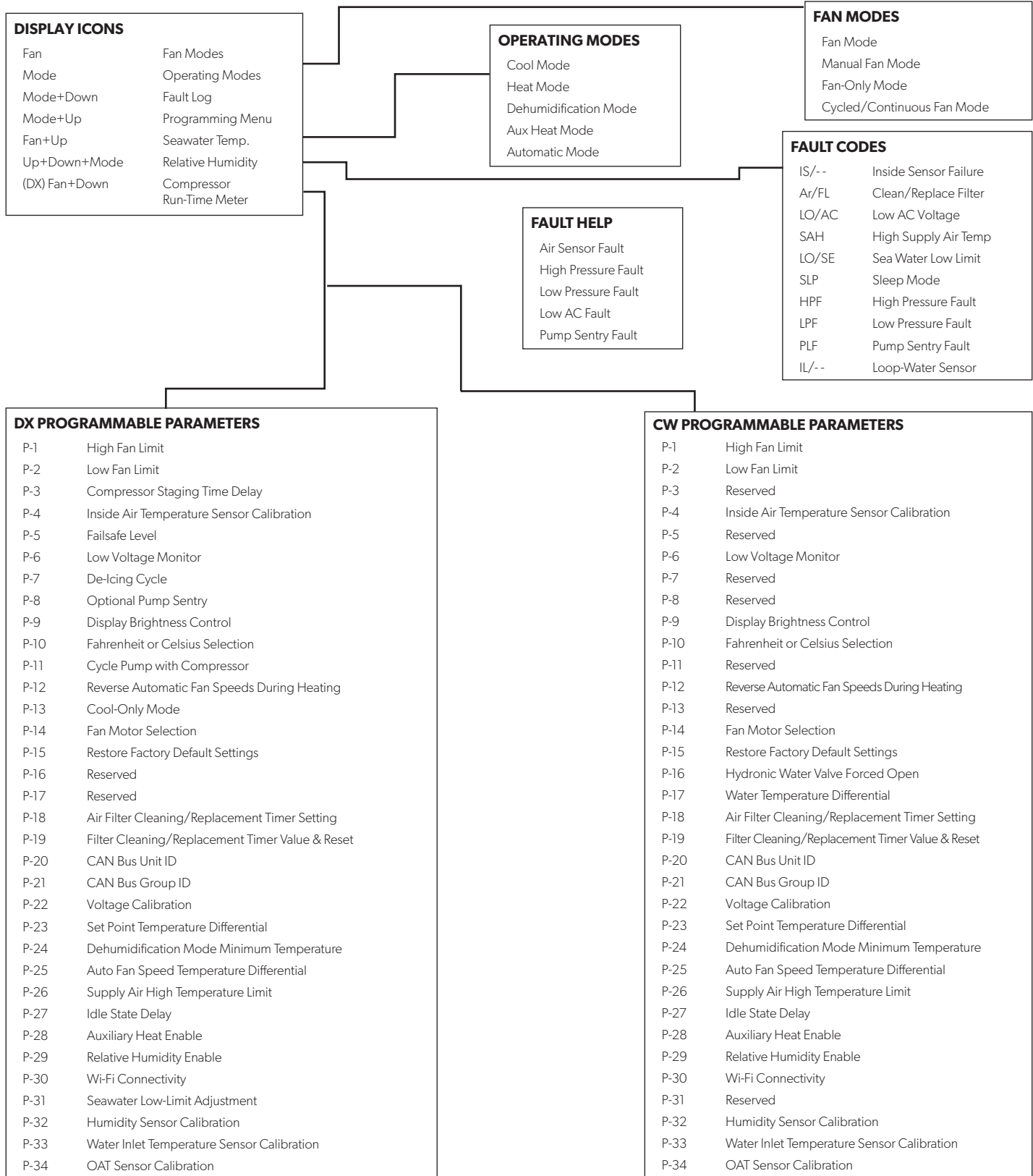



8 Troubleshooting

The following table describes some common occurrences that are not a result of defective workmanship or materials.

Problem	Possible Causes	Recommended Solution
The system does not power up.	The air conditioning unit circuit breaker is off.	Turn on the air conditioning unit circuit breaker at the ship's panel.
	The display is not turned on.	Turn on the display.
	The terminal strip is miswired.	Check the wiring diagram and correct if necessary.
	The input-line voltage is insufficient.	<ul style="list-style-type: none"> Check the power source (shore/generator) for proper voltage. Check the wiring and terminals for proper sizes and connections. Verify with a voltmeter that the power at the unit is the same as the power source.
	An electrical component has failed.	A technician should inspect the display, cable, and circuit board. Look for a red light on the circuit board.
The system runs continuously.	The unit is not able to reach the set point.	Close all the port holes and hatches. Adjust the set point so it is not too low for cooling or too high for heating.
	The seawater temperature is too high for cooling or too low for heating.	Seawater temperature will directly affect the air conditioning unit's efficiency. This air conditioning unit can effectively cool your boat in water temperatures up to 90 °F (32 °C) and heat (if reverse-cycle option is installed) in water as low as 40 °F (4 °C).
	The optional inside air temperature sensor is not located properly.	<ul style="list-style-type: none"> Verify the display location with the criteria found in the installation section of this manual. Install an optional inside air temperature sensor if necessary. If an optional inside air temperature sensor is already installed in the air stream, ensure it does not touch anything warm (like the condenser coil).
	The de-icing feature is not enabled.	Enable de-icing in the parameters. If ice still forms immediately, revisit the above possible causes.  Ice on a fan coil can be removed quickly by running the unit in heat mode.
There is a lack of airflow.	The airflow is blocked or restricted.	<ul style="list-style-type: none"> Remove any obstructions in the return-air stream. Clean the return-air filter and grille. Check for crushed or restricted ducting. Ducting must be as straight, smooth, and taut as possible.
	The fan speed is set to manual low.	<ul style="list-style-type: none"> If the fan speed is set to manual low, raise the speed to a higher setting or set to automatic mode. Or, increase the minimum low speed in the program parameters.
	The fan coil may be iced.	Refer to "The fan coil is iced" in this table.
The fan coil is iced.	The humidity level is set too high.	Close the hatches and doors.
	The supply air is short-cycling.	<ul style="list-style-type: none"> Redirect the supply air so that is not blowing in or near the return-air stream. Seal any air leaks on the duct.
	The airflow is blocked or restricted	Refer to "There is a lack of airflow" in this table.
	The fan runs too slow.	Set the fan speed to automatic mode or increase the manual fan speed. Or, increase the minimum low speed in the program parameters.
	The system runs continuously.	Close hatches and doors, raise set point, turn on de-icing.
The condenser coil is iced while in heat mode.	The seawater temperature is below 40 °F (4 °C).	<ul style="list-style-type: none"> Shut down the system to prevent damage to the condenser. Allow the coil to defrost.

Problem	Possible Causes	Recommended Solution
The fan does not run or runs continuously.	The digital control is set for either fan cycling with compressor or for continuous fan operation.	Change the fan operation to continuous fan operation or fan cycling with compressor. i When configured for auxiliary electric heat, the fan will stay on for four minutes after a heat cycle ends even if the fan is set to cycled operation.
	The circuit board on the unit is defective. Typically, the compressor and pump are still running.	Call for service to replace the board. i A shorted relay or triac may cause the fan to never shut off or never turn on. If the fan never shuts off, the fan may be set to 'continuous' on the display.
The unit does not heat.	The unit does not have a heating cycle.	Most units have a reverse cycle to create heat, but some units may not have this function.
	The display is set to cool-only or electric heat.	Change the parameters on the display or press the Mode button to activate heating or automatic. The auxiliary electric heat will not function if the display is set to auxiliary electric heat and the unit does not have an auxiliary electric heater added.
	The reversing valve is stuck.	<ul style="list-style-type: none"> Lightly tap on the valve with a rubber mallet while the unit is in heat mode. Call a service technician if that does not correct the problem.
	The seawater temperature is too low.	Seawater temperature directly affects the unit's efficiency. For the unit to heat (if the reverse-cycle option is available), water temperatures must be 40 °F (4 °C) or higher.
	There is a loss of refrigerant gas.	<ul style="list-style-type: none"> Check the air conditioning unit for a refrigerant oil leak. Call for service.
	(For CW systems only) The chilled-water loop is inadequately heated, the chiller system is not in the proper mode of operation, or the auxiliary electric heater is disabled.	<ul style="list-style-type: none"> Be sure the chiller is in heat mode. If the air handler system is equipped with water-temperature sensors, check the water temperature at the digital control. If the water temperature is not at least 15 °F warmer for heat mode, the water valve will not open. If the air handler system is equipped with an auxiliary electric heater, ensure that the auxiliary electric heat is enabled.
The unit does not cool.	The display is set to heat-only.	Change the parameters on the display or press the Mode button to activate cool or automatic mode.
	The seawater temperature is too high.	Seawater temperature will directly affect the air conditioning unit's efficiency. This air conditioning unit can effectively cool your boat in water temperatures up to 90 °F (32 °C). The unit may still work at higher water temperatures, but not as efficiently.
	There is a loss of refrigerant gas.	<ul style="list-style-type: none"> Check the air conditioning unit for a refrigerant oil leak. Call for service.
	(For CW systems only) The chilled-water loop is inadequately cooled or the chiller system is not in the proper mode of operation.	<ul style="list-style-type: none"> Be sure the chiller is in cool mode. If the air handler system is equipped with water-temperature sensors, check the water temperature at the digital control. If the water temperature is not at least 15 °F cooler for cool mode, the water valve will not open.
The unit switches to heat while in cool mode.	The de-icing feature is enabled due to the coil possibly icing up during long run times.	Reprogram the de-icing cycle under the parameter settings.
The pump does not shut off.	The circuit board is shorted.	<ul style="list-style-type: none"> Call service to verify if a relay on the circuit board is shorted or if the pump relay board is defective, if applicable. Replace any board that is shorted.
	The pump parameter on the display is set for the pump to run continuously.	Change the parameter on the display so the pump cycles with the compressor.
The pump does not run.	A high-pressure fault may be present.	Refer to "A high-pressure fault is present" in this table.

Problem	Possible Causes	Recommended Solution
The compressor does not shut off.	A relay on the circuit board has shorted closed.	Call service to verify and replace the board.
The compressor does not run.	A relay on the circuit board has shorted open.	Call service to verify and replace the board.
	There is an open overload on the compressor.	<ul style="list-style-type: none"> • Call service to verify and repair. • If the overload on the compressor is internal, wait several hours for it to cool before testing.
A low-pressure fault is present.	The unit does not have a low-pressure switch, but the JP2 jumper on the circuit board has been removed or a parameter, if applicable, has been enabled on the display.	<ul style="list-style-type: none"> • If the unit does not have a low-pressure switch, ensure the JP2 jumper on the board is in place over both pins. • Disable the parameter, if applicable.
	The low-pressure switch is open due to low seawater and/or low return-air temperatures.	Try to restart the air conditioning unit. The optional low-pressure switch has a ten-minute shutdown time delay that may be in effect.
	The low-pressure switch is open due to a loss of refrigerant.	<ul style="list-style-type: none"> • Check the air conditioning unit for a refrigerant oil leak. • Call for service.
	The low-pressure switch is defective or a wire is loose.	<ul style="list-style-type: none"> • Contact a servicing dealer to test the low-pressure switch and to ensure the wires are properly connected and seated in the orange plug on the circuit board. • Ensure the orange plug is not installed backwards on the circuit board.
A high-pressure fault is present.	The seawater flow is obstructed. The condenser coil may be too hot to touch.	<ul style="list-style-type: none"> • Water should be flowing strongly out of the overflow. Be sure the seacock is open and water is flowing to the pump. • Clean the seawater strainer. • Check for obstructions at the speed scoop thru-hull inlet. • Check for a strong, steady flow from the overboard discharge.
	The high-pressure switch is open (in heating) due to improper airflow.	<ul style="list-style-type: none"> • Remove any obstructions in the return-air stream. • Clean the air filter and grille. • Check for crushed or restricted ducting. The ducting must be as straight, smooth, and as taut as possible. • If the problem persists, reprogram the low fan speed limit for maximum value. • Set the low fan limit to 75, and set the reverse fan speeds during heat mode by changing the reverse fan speed in Heat under general settings, or manually set the fan speed to high.
	The high-pressure switch is open (in heating) due to a high seawater temperature.	The system may cycle on high-pressure if the seawater temperature is above 55 °F (13 °C).
	The high-pressure switch is defective or a wire is loose.	<ul style="list-style-type: none"> • Contact a servicing dealer to test the high-pressure switch and to ensure the wires are properly connected and seated in the orange plug on the circuit board. • Ensure the orange plug is not installed backwards on the circuit board.
	The seawater pump may be air-locked.	<ul style="list-style-type: none"> • Ensure that the seawater plumbing is installed according to the guidelines in the installation manual included with the air conditioning unit. • Remove the hose from the pump discharge to purge air from the line.
	The seawater pump is not running.	<ul style="list-style-type: none"> • Water should be strongly flowing out of the overflow . • Ensure the pump is not damaged from being run dry. • Check if the pump is receiving voltage. • Check the pump circuit breaker or the relay board, if applicable.

Problem	Possible Causes	Recommended Solution
A low-AC voltage fault is present.	The supply voltage is too low.	Use a multimeter to verify that constant, steady power is available to the unit.
	The voltage is improperly calibrated, if applicable.	<ul style="list-style-type: none"> Use a multimeter to verify that the voltage reading to the unit matches the voltage calibration in the parameters. Adjust the voltage calibration if necessary.
The air conditioning unit does not respond to the changes entered on the display.	The display is experiencing a power interruption, voltage frequency fluctuation, electromagnetic interference from other equipment, or similar power-related issue.	Perform a factory reset of the display: <ol style="list-style-type: none"> Turn the power off. Disconnect the cable from the display. Turn the power on, wait 20 seconds, and turn the power off. Reconnect the cable to the display. Turn the power on.
	The circuit board is recognizing previously connected displays.	 This will cause all the parameters to reset to the factory default settings.
	The display-cable plugs are not making contact (for example, the plugs are unplugged, dirty, bent, or have broken pins). The display may show '999' or '---' if unable to communicate with the unit.	<ul style="list-style-type: none"> With the power off at the circuit breaker, remove the connector and inspect it. Clean the socket and the cable with electrical contact cleaner. Work the cable in and out of the socket. If damaged, replace the connector or the display cable.
	The display buttons do not function.	The display is locked. Unlock the display.
	The display and the circuit board are not compatible.	<ul style="list-style-type: none"> Ensure the compatibility between the circuit board and the display. Some older boards will not work with newer displays and some newer boards will not work with older displays. If the rebooted circuit board and display unit continue to act oddly, replace the display cable.
The display does not show the correct room temperature.	The display is showing a code for a faulty air sensor, typically because there is a failed: display built-in temperature sensor, optional inside air temperature sensor, or display cable.	<ul style="list-style-type: none"> Replace the optional inside air temperature sensor. If using the display built-in temperature sensor, replace the display or add an optional inside air temperature sensor. Install a different display cable. Ensure that the damaged jack/socket in the display head or on the circuit board is not damaged.
	The temperature displayed is too high.	<ul style="list-style-type: none"> If the temperature displayed is within 50 °F above the actual temperature, use calibration parameter 4 to adjust. If the temperature displayed is hotter than 50 °F above the actual temperature, adjust the JP5 jumper on the unit's circuit board. Refer to the optional inside air temperature sensor note.
	The temperature displayed is too low.	<ul style="list-style-type: none"> If the temperature displayed is within 50 °F below the actual temperature, use calibration parameter 4 to adjust. If the temperature displayed is colder than 50 °F below the actual temperature, adjust the JP5 jumper on the unit's circuit board. Refer to the optional inside air temperature sensor note.
	The temperature adjusts too quickly or still does not read correctly.	Relocate the display or the optional inside air temperature sensor. The supply air should not blow on or near a sensor. Locate optional inside air temperature sensors in the return air stream, not physically touching any part of the unit.  Optional inside air temperature sensor note: if the unit uses an optional inside air temperature sensor, it will be either an RJ11 4-pin 3,000 K sensor or an RJ12 6-pin 10,000 K sensor. If the 6-pin sensor is installed, the JP5 jumper must be removed from the board. If neither sensor is installed on the circuit board, the display reads from its own built-in sensor, if applicable.

Problem	Possible Causes	Recommended Solution
A low pump-flow fault is present, if applicable.	The condenser coil is too hot.	Verify the unit receives water flow and the condenser is not fouled.
	The thermistor is damaged.	<ul style="list-style-type: none"> • Unplug the water sensor if installed. • Install another thermistor if one is available.
	There is a damaged jack/socket on the circuit board.	Visually check to verify the pins inside the socket are not bent or corroded. Repair or replace the circuit board if needed.
A filter reminder is presented.	The timer setting to clean or replace the filter has been reached.	Clean or replace the filter and reset the filter hours.

9 Disposal



Place the packaging material in the appropriate recycling waste bins, whenever possible. Consult a local recycling center or specialist dealer for details about how to dispose of the product in accordance with all applicable national and local regulations.

10 Warranty Information

LIMITED WARRANTY AVAILABLE AT WWW.DOMETIC.COM/WARRANTY.

IF YOU HAVE QUESTIONS, OR TO OBTAIN A COPY OF THE LIMITED WARRANTY FREE OF CHARGE, CONTACT:

DOMETIC CORPORATION
 MARINE CUSTOMER SUPPORT CENTER
 2000 NORTH ANDREWS AVENUE
 POMPANO BEACH, FLORIDA, USA 33069
 1-800-542-2477

Mobile living made easy.



dometic.com

**YOUR LOCAL
DEALER**

dometic.com/dealer

**YOUR LOCAL
SUPPORT**

dometic.com/contact

**YOUR LOCAL
SALES OFFICE**

dometic.com/sales-offices

A complete list of Dometic companies, which comprise the Dometic Group, can be found in the public filings of:
DOMETIC GROUP AB Hemvärnsgatan 15 SE-17154 Solna Sweden